



Quality Access Doors- FAST!

SUBMITTAL/TECHNICAL DATA SHEET

APPLICATIONS

Indoor or Outdoor applications where dirt and water are prevented from falling into work area. Drainage is provided through threaded coupling in channel

FEATURES

- Channel frame construction with 1 1/2" drainage coupling and integral anchor flange is designed to be cast into concrete
- Diamond plate door panel is equipped with a flush aluminum drop handle and an automatic hold open arm
- Designed for off-street locations that may occasionally receive AASHTO H 20-44 wheel loads

SPECIFICATIONS

MATERIAL: Aluminum door and frame; stainless steel hinges and hardware

DOOR: 1/4" aluminum diamond plate reinforced to meet AASHTO specification H 20-44 for traffic loading (16000 lb. wheel load with 30% added for impact)

HINGE: Stainless steel butt hinges with tamperproof stainless steel bolts and nuts

FRAME: Channel frame fabricated from aluminum extrusion with 1 1/2" drainage coupling and integral 1" anchor flange

OPENING DEVICE: Automatic hold open arm with red vinyl grip allows door panel to open to 90 degrees, locking door in open position, and allowing for easy control when closing door panel. When required, stainless steel compression springs can be provided to add lift assistance. Available with electrical actuators, operated by wall mounted push button switch, and remote control

STANDARD LATCH: Flush aluminum drop handle with stainless steel slamlock

FINISH: Mill finish, with bituminous coating on exterior of frame

SKU: **BAC-WTFD-H20**

WATERTIGHT FLOOR HATCH

WITH H2O LOADING



DIMENSIONS AND APPEARANCE

>> CLICK TO VIEW ADDITIONAL DETAILS AND PRICING <<

DOOR SIZE W x H INCHES (MM)	WEIGHT	
	LBS	KG
24 x 24 (610 x 610)	62	28
24 x 30 (610 x 762)	70	32
24 x 36 (610 x 914)	87	39
30 x 30 (762 x 762)	86	39
30 x 36 (762 x 914)	101	46
36 x 36 (914 x 914)	122	55
36 x 48 (914 x 1219)	120	56
42 x 42 (1067 x 1067)	125	57
*48 x 48 (1219 x 1219)	221	100
*48 x 72 (1219 x 1829)	330	150
*60 x 60 (1524 x 1524)	399	181

* DOUBLE LEAF

For detailed specifications see submittal sheet

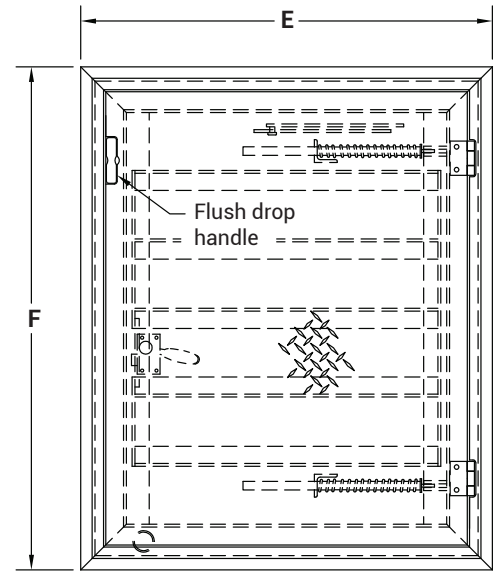
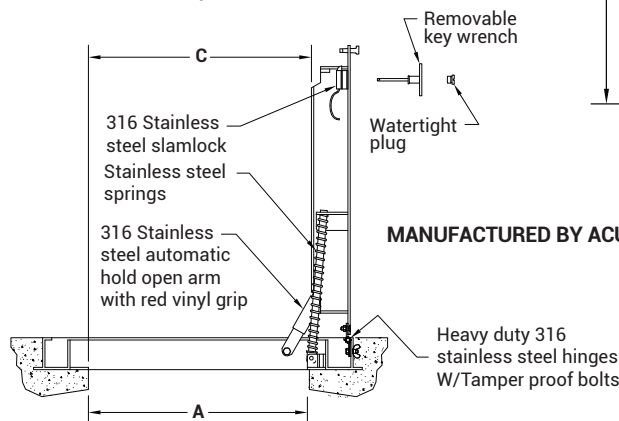

Odor reduction gasket

1/4" Extruded trough section with Integral continuous anchor flange & groove for gasket frame MAT'L: aluminum 6063-TS

MANUFACTURED BY ACUDOR

For a complete list of options visit www.BestAccessDoors.ca

PROJECT DATA

Custom Sizes Available - Fast!

Scan or Click



To view Pricing and Additional Product Info.

PROJECT NAME :	QTY	W	H	OPTIONS
ARCHITECT :				
DEALER :				
CONTRACTOR :				
LOCATION :	SPECIAL INSTRUCTIONS :			
DATE :				
TAGGING INSTRUCTIONS :	SUBMITTAL APPROVAL : (signature or stamp)			

TELEPHONE:
1-800-483-0823

FAX:
1-888-828-6021

385 WILSON STREET EAST,
SUITE 302
ANCASTER, ON, L9G 2C1
CANADA



WEBSITE:
www.BestAccessDoors.ca

E-MAIL:
info@bestaccessdoors.ca

BAC-WTFD-H20

WATERTIGHT FLOOR HATCH WITH H20 LOADING - SINGLE LEAF

NOMINAL DOOR SIZE	FRAME OPENING		CLEAR OPENING		OVERALL SIZE		WEIGHT
in. (mm)	A in. (mm)	B in. (mm)	C in. (mm)	D in. (mm)	E in. (mm)	F in. (mm)	LBS. (KG)
24 x 24 (610 x 610)	24 (610)	24 (610)	22 (559)	23 (584)	34 (864)	30 (762)	62 (28)
24 x 30 (610 x 762)	24 (610)	30 (762)	22 (559)	29 (737)	34 (864)	36 (914)	70 (32)
24 x 36 (610 x 914)	24 (610)	36 (914)	22 (559)	35 (889)	34 (864)	42 (1067)	87 (39)
30 x 30 (762 x 762)	30 (762)	30 (762)	28 (711)	29 (737)	40 (1016)	36 (914)	86 (39)
30 x 36 (762 x 914)	30 (762)	36 (914)	28 (711)	35 (889)	40 (1016)	42 (1067)	101 (46)
36 x 36 (914 x 914)	36 (914)	36 (914)	32 (838)	35 (889)	46 (1168)	42 (1067)	122 (55)
36 x 48 (914 x 1219)	36 (914)	48 (1219)	34 (864)	47 (1193)	46 (1168)	54 (1371)	120 (56)
42 x 42 (1067 x 1067)	42 (1067)	42 (1067)	40 (1016)	41 (1041)	52 (1320)	48 (1219)	125 (57)

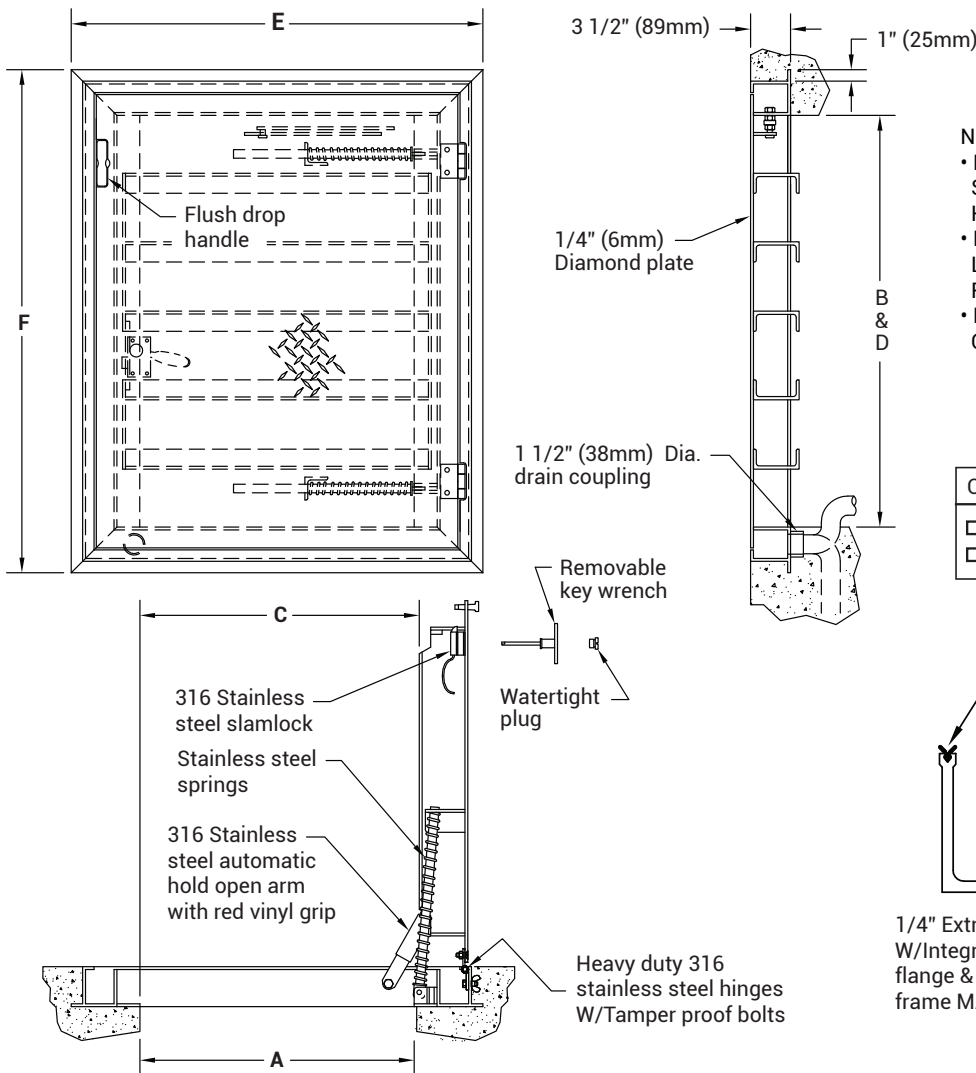

NOTES:

- MATERIAL: ALUMINUM WITH STAINLESS STEEL SPRINGS, 316 STAINLESS STEEL NUTS & BOLTS, HINGES AND HOLD OPEN ARM.
- LOADING: DESIGNED FOR OFF-STREET LOCATIONS WHICH MAY OCCASIONALLY RECEIVE H-20 WHEEL LOADS.
- BITUMINOUS COATING IS APPLIED TO AREA OF FRAME IN CONTACT WITH CONCRETE.

OPTIONAL FEATURES

- RECESSED STAPLE FOR PADLOCK
- OTHERS: _____

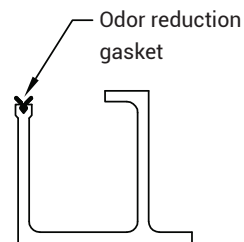

1/4" Extruded trough section W/Integral continuous anchor flange & groove for gasket frame MAT'L: aluminum 6063-TS

BAC-WTFD-H20

WATERTIGHT FLOOR HATCH WITH H2O LOADING - DOUBLE LEAF

NOMINAL DOOR SIZE	FRAME OPENING		CLEAR OPENING		OVERALL SIZE		WEIGHT
	in. (mm)	A in. (mm)	B in. (mm)	C in. (mm)	D in. (mm)	E in. (mm)	F in. (mm)
48 x 48 (1219 x 1219)	48 (1219)	48 (1219)	48 (1219)	36 (914)	59 (1499)	54 (1372)	221 (100)
48 x 72 (1219 x 1829)	48 (1219)	72 (1829)	48 (1219)	60 (1524)	59 (1499)	78 (1981)	330 (150)
60 x 60 (1524 x 1524)	60 (1524)	60 (1524)	60 (1524)	44 (1118)	71 (1803)	66 (1676)	399 (181)

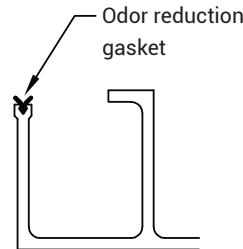
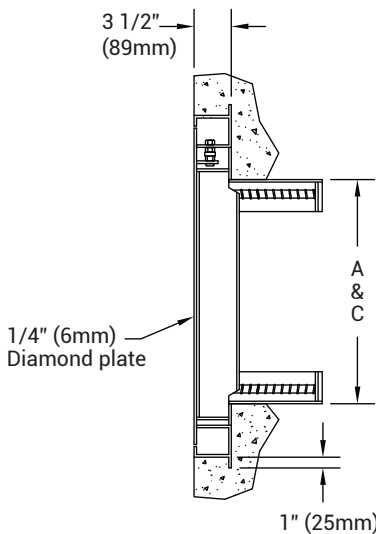
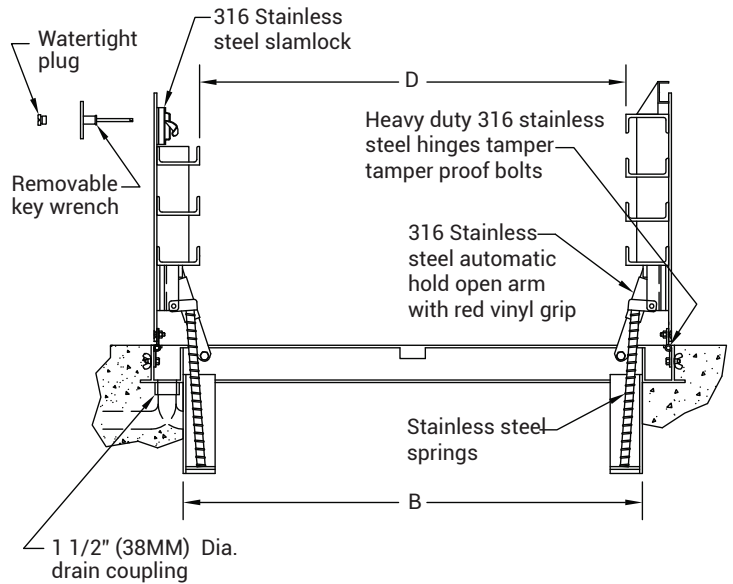
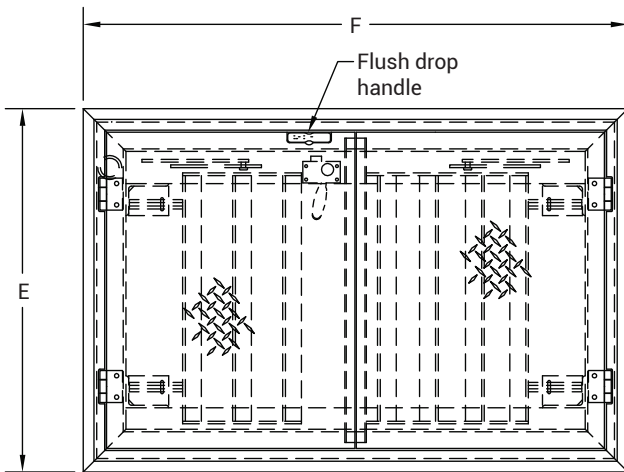

1/4" Extruded trough section
W/Integral continuous anchor
flange & groove for gasket
frame MAT'L: aluminum 6063-TS

NOTES:

- MATERIAL: ALUMINUM WITH STAINLESS STEEL SPRINGS, 316 STAINLESS STEEL NUTS & BOLTS, HINGES AND HOLD OPEN ARM.
- LOADING: DESIGNED FOR OFF-STREET LOCATIONS WHICH MAY OCCASIONALLY RECEIVE H-20 WHEEL LOADS.
- BITUMINOUS COATING IS APPLIED TO AREA OF FRAME IN CONTACT WITH CONCRETE.

OPTIONAL FEATURES

- RECESSED STAPLE FOR PADLOCK
 OTHERS: _____