



Quality Access Doors- FAST!

# SUBMITTAL/TECHNICAL DATA SHEET

## STANDARD OPTIONS

- MATERIAL :**  
Stainless Steel
- HINGE:**  
Hidden pin hinge  
continuous piano type on doors  
over 24" (height or width)
- LOCK / LATCH:**  
Screwdriver operated cam latch
- FINISH:**  
High quality white powder coat  
primer
- PACKAGING:**  
Individually wrapped, 1 per box

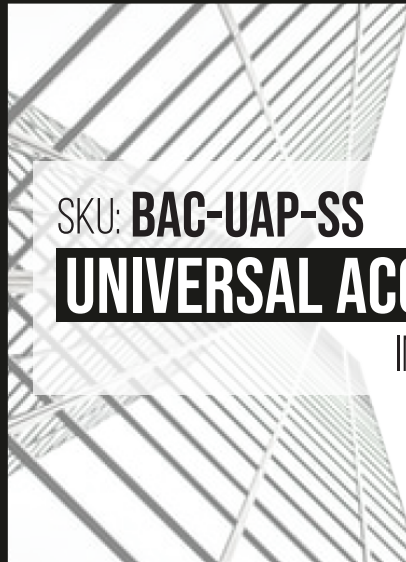

SKU: **BAC-UAP-SS**

## UNIVERSAL ACCESS PANEL

IN STAINLESS STEEL



## OPTIONS AVAILABLE

- LOCK / LATCH:**
- Key operated cylinder cam latch
  - Hex head cam latch
  - Pinned hex head cam latch
  - Handle operated cam latch
  - Mortise preparation for cylinder

**GASKETING:**  
Neoprene gasket

## INSTALLATION

>> CLICK TO VIEW ADDITIONAL DETAILS AND PRICING <<

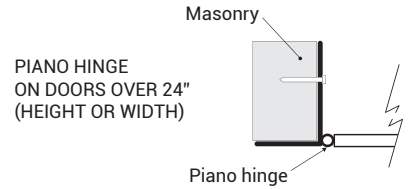
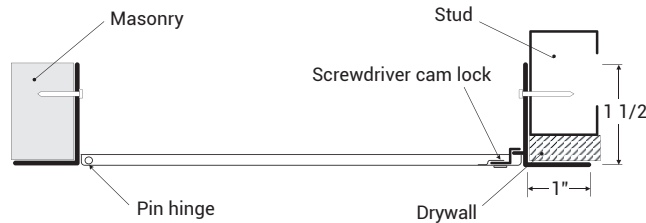

## DIMENSIONS AND APPEARANCE

DOOR SIZE W x H INCHES (MM)	NUMBER OF LOCKS	WEIGHT LBS KG
6 x 6 (152 x 152)	1	2 0.9
8 x 8 (203 x 203)	1	3 1.4
8 x 12 (203 x 304)	1	4 1.8
10 x 10 (254 x 254)	1	4 1.8
12 x 12 (304 x 304)	1	5 2.3
12 x 16 (304 x 406)	1	6.2 2.8
12 x 18 (304 x 457)	1	7 3.2
12 x 24 (304 x 609)	1	8 3.6
14 x 14 (356 x 356)	1	7 3.2
16 x 16 (406 x 406)	1	8 3.6
18 x 18 (457 x 457)	1	9 4.1
18 x 24 (457 x 609)	1	13 5.9
20 x 20 (508 x 508)	1	11 5
22 x 22 (558 x 558)	1	13 5.9
* 22 x 30 (558 x 762)	2	17 7.7
* 22 x 36 (558 x 914)	2	19 8.6
* 24 x 24 (609 x 609)	1	15 6.8
* 24 x 30 (609 x 762)	2	20 9.1
* 24 x 36 (609 x 914)	2	22 10
* 24 x 48 (609 x 1219)	2	28 12.7
* 30 x 30 (762 x 762)	4	23 12.7
* 36 x 36 (914 x 914)	4	31 14.1

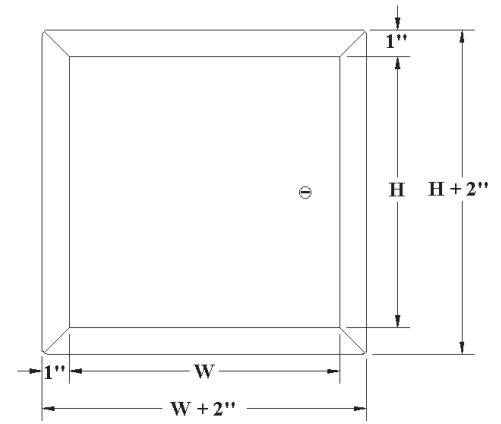

ROUGH WALL OPENING IS DOOR SIZE + 1/4" OR + 6MM  
\* Piano hinge on doors over 24 inches (height or width)  
The BA-LHD model is recommended for over 1296 sq. inches

For a complete list of options visit  
[www.BestAccessDoors.ca](http://www.BestAccessDoors.ca)

Scan or Click



To view Pricing and  
Additional Product Info.

LEED READY: THIS PRODUCT  
CONTRIBUTES TO LEED® CREDITS



## PROJECT DATA

Custom Sizes Available - Fast!

PROJECT NAME :	QTY	W	H	OPTIONS
ARCHITECT :				
DEALER :				
CONTRACTOR :				
LOCATION :	SPECIAL INSTRUCTIONS :			
DATE :				
TAGGING INSTRUCTIONS :	SUBMITTAL APPROVAL : (signature or stamp)			

TELEPHONE:  
1-800-483-0823

FAX:  
1-888-828-6021

385 WILSON STREET EAST,  
SUITE 302  
ANCASTER, ON, L9G 2C1  
CANADA

WEBSITE:  
[www.BestAccessDoors.ca](http://www.BestAccessDoors.ca)

E-MAIL:  
[info@bestaccessdoors.ca](mailto:info@bestaccessdoors.ca)

