



Quality Access Doors- FAST!

# SUBMITTAL/TECHNICAL DATA SHEET

## APPLICATION

- Simple to install and easy to operate
- Cost-effective choice for large structures – stock up on this one!
- Designed for airports, stadiums, and large capacity buildings
- Reduces sagging and requires fewer locks
- Flush, professional finish for commercial use
- Provides easy access for hassle-free maintenance and repairs

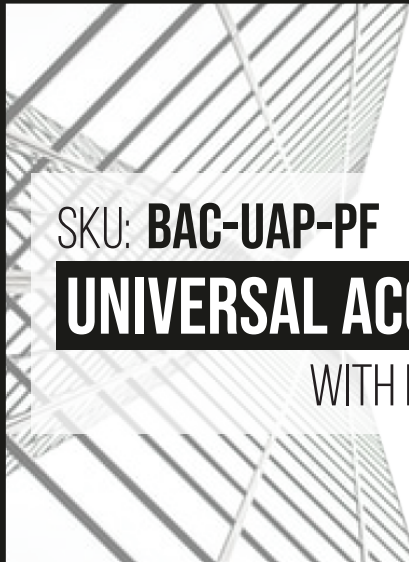

SKU: **BAG-UAP-PF**

## UNIVERSAL ACCESS PANEL

WITH PLASTER FLANGE



## SPECIFICATIONS

**MATERIAL:** 16-gauge cold rolled steel door and 22-gauge galvanized steel drywall bead flange

**DOOR:** Flush to frame with reinforced edges

**FRAME:** 1 1/2" in depth, made of cold rolled steel

**FLANGE:** 22-gauge galvanized steel, 1" drywall bead flange

**HINGE:** Cold rolled steel pin hinge

**LATCH:** Screwdriver operated cam latch in cold rolled steel

**FINISH:** High quality white powder coat primer

**PACKAGING:** Individually wrapped, 1 door per box

## INSTALLATION

>> [CLICK TO VIEW ADDITIONAL DETAILS AND PRICING <<](#)

### STANDARD SIZES:

DOOR SIZE W x H INCHES (MM)	LATCHES	WEIGHT	
		LBS	KG
8 x 8 (203 x 203)	1	3	1.4
10 x 10 (254 x 254)	1	4	1.8
12 x 12 (304 x 304)	1	5	2.3
14 x 14 (356 x 356)	1	7	3.2
16 x 16 (406 x 406)	1	8	3.6
18 x 18 (457 x 457)	1	10	4.5
* 24 x 24 (609 x 609)	1	15	6.8
* 24 x 36 (609 x 914)	2	22	10

Rough opening Door sizes + 1/4" or + 6mm

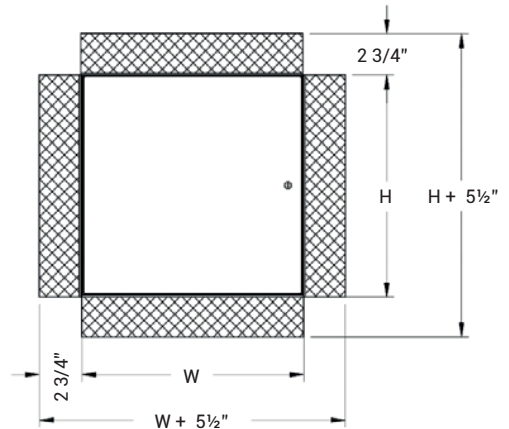

## DIMENSIONS AND APPEARANCE

For a complete list of options visit [www.BestAccessDoors.ca](http://www.BestAccessDoors.ca)

Scan or Click



To view Pricing and Additional Product Info.

**LEED READY: THIS PRODUCT CONTRIBUTES TO LEED® CREDITS**

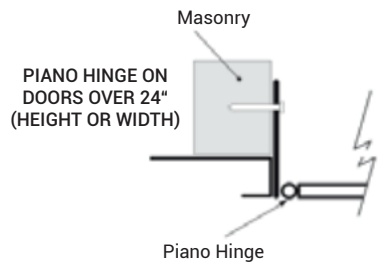
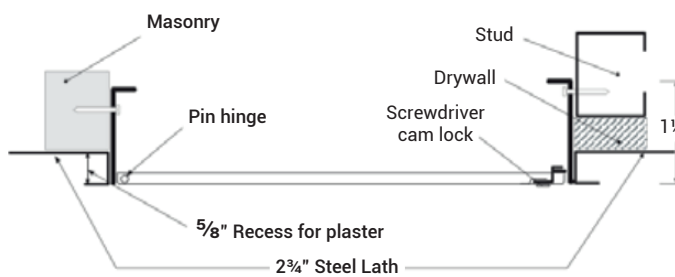

## PROJECT DATA

**Custom Sizes Available - Fast!**

PROJECT NAME :	QTY	W	H	OPTIONS
ARCHITECT :				
DEALER :				
CONTRACTOR :				
LOCATION :	SPECIAL INSTRUCTIONS :			
DATE :				
TAGGING INSTRUCTIONS :	SUBMITTAL APPROVAL : (signature or stamp)			



TELEPHONE:  
1-800-483-0823  
FAX:  
1-888-828-6021



385 WILSON STREET EAST,  
SUITE 302  
ANCASTER, ON, L9G 2C1  
CANADA



WEBSITE:  
[www.BestAccessDoors.ca](http://www.BestAccessDoors.ca)  
E-MAIL:  
[info@bestaccessdoors.ca](mailto:info@bestaccessdoors.ca)