



Quality Access Doors - FAST!

SUBMITTAL/TECHNICAL DATA SHEET

Door and Frame shall be 16 gauge galvanized steel with a prime coat finish.

Frame is a one piece construction 1" wide and produces perfect concealment of the rough wall openings. Wall frame is provided with 1/4" mounting holes for fastening within the furred spaces allowing faster installation and giving maximum clearance.

Hinge is a concealed continuous piano hinge.

Latch is screwdriver operated.

Finish is a prime coat suitable for painting.



SKU: **BAC-RVB**
VALVE BOX



DIMENSIONS AND APPEARANCE

>> CLICK TO VIEW ADDITIONAL DETAILS AND PRICING <<

GUIDE SPECIFICATION

Valve Box (specify model number and options) access door and frame shall be fabricated from 16 gauge, galvanized steel with a prime coat finish. The door shall have rounded safety corners and a concealed continuous piano hinge. Frame shall be one piece construction with no mitres or welds on the face. Latch shall be screwdriver operated. Elmdor Valve Box shall be fully enclosed with 16 gauge, galvanized steel with a prime coat finish. Finish shall be a prime coat suitable for painting.

STANDARD SIZES:

DOOR SIZE (W x H)	WALL OPENING	LATCH	WEIGHT LBS
VB 8" x 8" x 4"	8-1/2" x 8-1/2"	1	10.0 LBS.
VB 8" x 8" x 6"	8-1/2" x 8-1/2"	1	12.0 LBS.
VB 12" x 12" x 4"	12-1/2" x 12-1/2"	1	18.0 LBS.
VB 12" x 12" x 6"	12-1/2" x 12-1/2"	1	20.0 LBS.
VB 14" x 14" x 4"	14-1/2" x 14-1/2"	1	26.0 LBS.
VB 14" x 14" x 6"	14-1/2" x 14-1/2"	1	28.0 LBS.
VB 16" x 16" x 4"	16-1/2" x 16-1/2"	1	32.0 LBS.
VB 16" x 16" x 6"	16-1/2" x 16-1/2"	1	34.0 LBS.

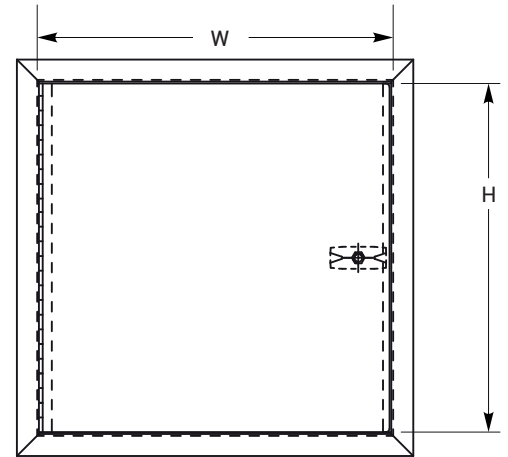

MODEL NUMBER AND OPTIONS SELECTION

BASE MODEL NUMBER

-VB Valve Box

SUFFIX OPTIONS

- AKL Allen Key Latch
- CL Cylinder Lock
- CLD Cylinder Lock with Dust Shutter
- SS Stainless Steel Construction. (Type 304 No. 4 Satin Finish)
- TH T Handle

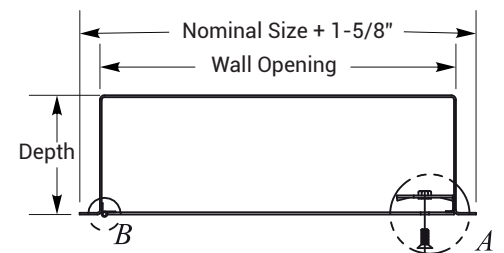
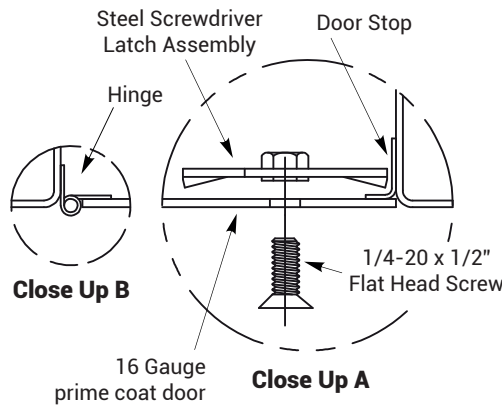

For a complete list of options visit www.BestAccessDoors.ca

PROJECT DATA

Custom Sizes Available - Fast!

Scan or Click



To view Pricing and Additional Product Info.

PROJECT NAME :	QTY	W	H	OPTIONS
ARCHITECT :				
DEALER :				
CONTRACTOR :				
LOCATION :	SPECIAL INSTRUCTIONS :			
DATE :	SUBMITTAL APPROVAL : (signature or stamp)			
TAGGING INSTRUCTIONS :				

TELEPHONE:
1-800-483-0823
FAX:
1-888-828-6021



385 WILSON STREET EAST,
SUITE 302
ANCASTER, ON, L9G 2C1
CANADA



WEBSITE:
www.BestAccessDoors.ca
E-MAIL:
info@bestaccessdoors.ca