



Quality Access Doors - FAST!

SUBMITTAL/TECHNICAL DATA SHEET

APPLICATION

Designed for interior and exterior applications that require an access opening that will blend in with the surrounding floor material

FEATURES

- Recessed 1" to accommodate ceramic tile/concrete
- To keep the floor material from cracking or chipping within the door panel, the security screws are located in the flange of the mounting frame

SPECIFICATIONS

MATERIAL: Aluminum

DOOR: 1/4" smooth aluminum plate reinforced for live loads of 150 pounds/sq.ft. / recessed 1" for ceramic tile/concrete

FRAME: 1-1/2" x 1-1/4" aluminum angle with mounting holes in top flange

STANDARD LATCH: Door panel is secured to frame with 1/4" x 1" flat head screws

FINISH: Mill finish

SKU: **BAC-RRFD-T1**

REMOVABLE FLOOR HATCH RECESSED 1"

FOR CERAMIC TILE

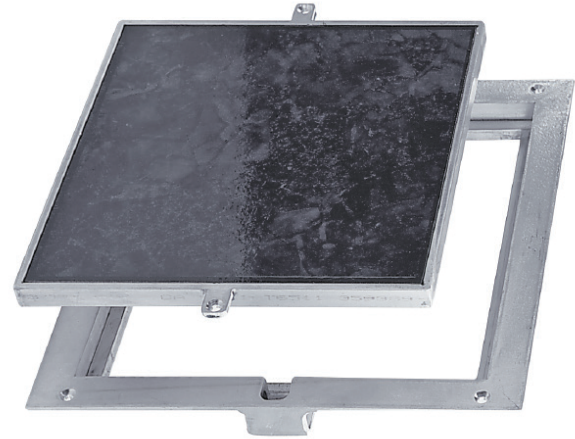

DIMENSIONS AND APPEARANCE

>> [CLICK TO VIEW ADDITIONAL DETAILS AND PRICING <<](#)

DOOR SIZE W x H INCHES (MM)	WEIGHT	
	LBS	KG
8 x 8 (203 x 203)	6	2.7
12 x 12 (305 x 305)	9	4.1
18 x 18 (457 x 457)	18	8.2
24 x 24 (610 x 610)	36	16.3

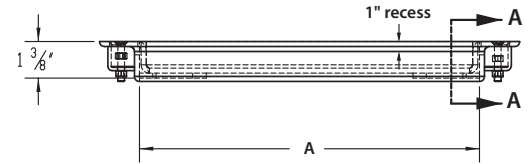

For detailed specifications see submittal sheet

MANUFACTURED BY ACUDOR

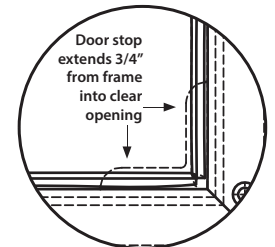
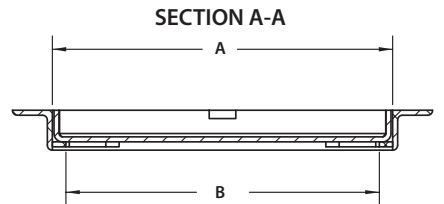
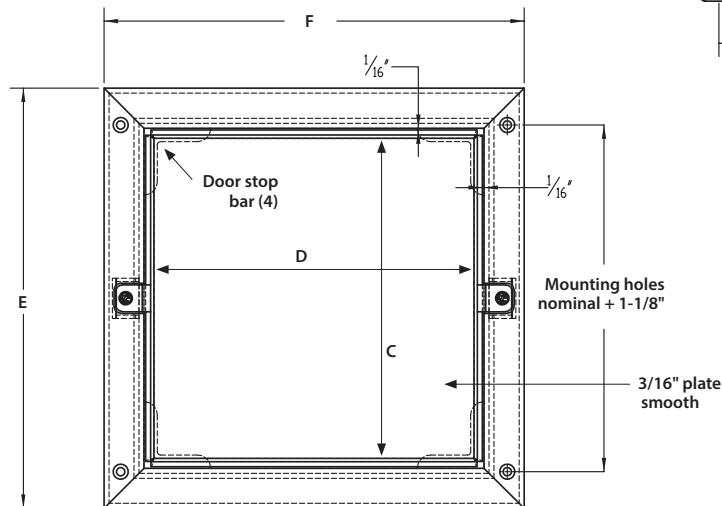

DOOR STOP DETAIL

- NOTES:
- MATERIAL: ALUMINUM
 - LOADING: 150 LBS. PER SQ. FT.
 - 316 STAINLESS STEEL NUTS & BOLTS

For a complete list of options visit www.BestAccessDoors.ca

PROJECT DATA

Custom Sizes Available - Fast!

PROJECT NAME :	QTY	W	H	OPTIONS
ARCHITECT :				
DEALER :				
CONTRACTOR :				
LOCATION :	SPECIAL INSTRUCTIONS :			
DATE :				
TAGGING INSTRUCTIONS :	SUBMITTAL APPROVAL : (signature or stamp)			

Scan or Click



To view Pricing and Additional Product Info.

TELEPHONE:
1-800-483-0823

FAX:
1-888-828-6021

385 WILSON STREET EAST,
SUITE 302
ANCASTER, ON, L9G 2C1
CANADA



WEBSITE:
www.BestAccessDoors.ca

E-MAIL:
info@bestaccessdoors.ca

BAC-RRFD-T1

REMOVABLE FLOOR HATCH RECESSED 1" FOR CERAMIC TILE

NOMINAL DOOR SIZE	FRAME OPENING		RECEIVING AREA		OVERALL SIZE		WEIGHT
	A in. (mm)	B in. (mm)	C in. (mm)	D in. (mm)	E in. (mm)	F in. (mm)	LBS. (KG)
8 x 8	8.750 (222)	7.750 (222)	8.125 (206)	8.125 (206)	11.750 (298)	11.750 (298)	5 (2.2)
12 x 12	12.750 (324)	11.750 (324)	12.125 (308)	12.125 (308)	15.750 (476)	15.750 (476)	7 (3.2)
18 x 18	18.750 (476)	17.750 (476)	18.125 (460)	18.125 (460)	21.750 (552)	21.750 (552)	15 (6.8)
24 x 24	24.750 (629)	23.750 (629)	24.125 (613)	24.125 (613)	27.750 (705)	27.750 (705)	36 (16.3)

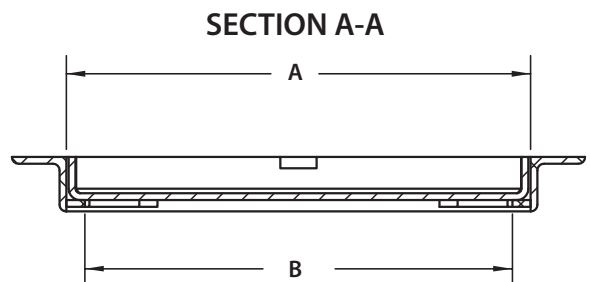
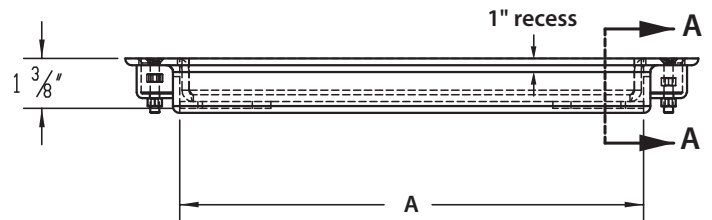
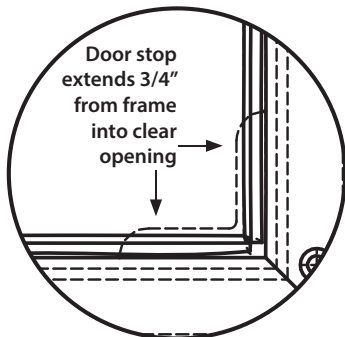
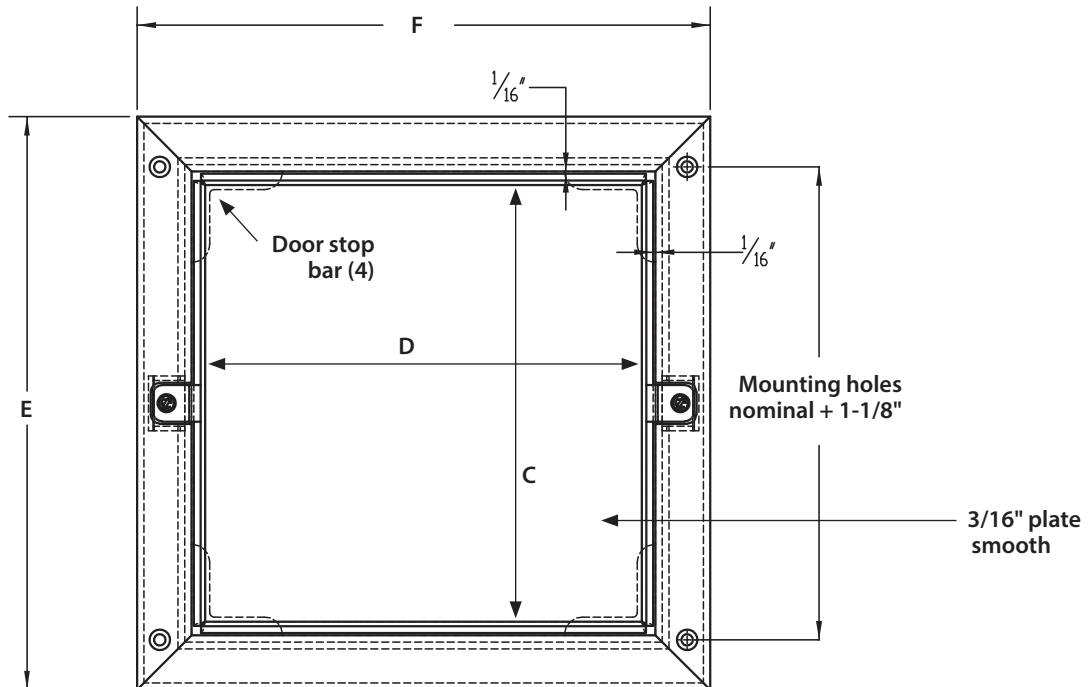

- NOTES:
- MATERIAL: ALUMINUM
 - LOADING: 150 LBS. PER SQ. FT.
 - 316 STAINLESS STEEL NUTS & BOLTS