



Quality Access Doors- FAST!

SUBMITTAL/TECHNICAL DATA SHEET

DESCRIPTIONS

Constructed of heavier gauge materials for high security applications such as prisons, banks, embassies, and pharmaceutical buildings. Roof hatches can be fabricated for field installation of many leading brands of security locks. Other options include security glazing and gun ports.

SPECIFICATIONS

MATERIAL:
 Steel: Cover and frame are 3/16" (4.76mm) steel
 Aluminum: Cover and frame are 3/16" (4.76mm) aluminum

COVER:
 Brakeformed, hollow-metal design with 1" (25.4mm) concealed fiberglass insulation, 3" (76mm) beaded, overlapping flange, fully welded at corners, and internally reinforced for 40 psf (195 kg/m²) live load

CURB:
 12" (305mm) in height with integral capflashing, 1" (25.4mm) fiberboard insulation, fully welded at corners, and 3-1/2" (89mm) mounting flange with 7/16" holes (11 mm) provided for securing frame to the roof deck

GASKET:
 Extruded EPDM rubber gasket permanently adhered to the cover

HINGES:
 Heavy-duty aluminum bronze hinges

LATCH:
 Factory prepared to receive a deadbolt detention lock (specify manufacturer and model #), supplied and installed by others in the field. Consult factory if an alternate lock is required.

LIFT ASSISTANCE:
 Compression spring operators enclosed in telescopic tubes. Automatic hold-open arm with grip handle release.

FINISH:
 Steel: Alkyd base red oxide primer
 Aluminum: Mill finish

For a complete list of options visit www.BestAccessDoors.ca

SKU: BAC-NB-50C SECURITY ROOF ACCESS HATCH



DIMENSIONS AND APPEARANCE

>> CLICK TO VIEW ADDITIONAL DETAILS AND PRICING <<

STANDARD SIZES AND WEIGHTS

SIZE		STEEL			ALUMINUM				
Weight x Length		Model #	Weight		Open Angle	Model #	Weight		
inches	mm		lbs.	kg.			lbs.	kg.	Open Angle
36 X 30	914 X 762	S-20C	386	175	70°	S-50C	150	68	70°
30 X 36	914 X 914	E-20C	400	181	70°	E-50C	176	80	70°
30 X 54	762 X 1372	NB-20C	475	215	90°	NB-50C	210	95	90°

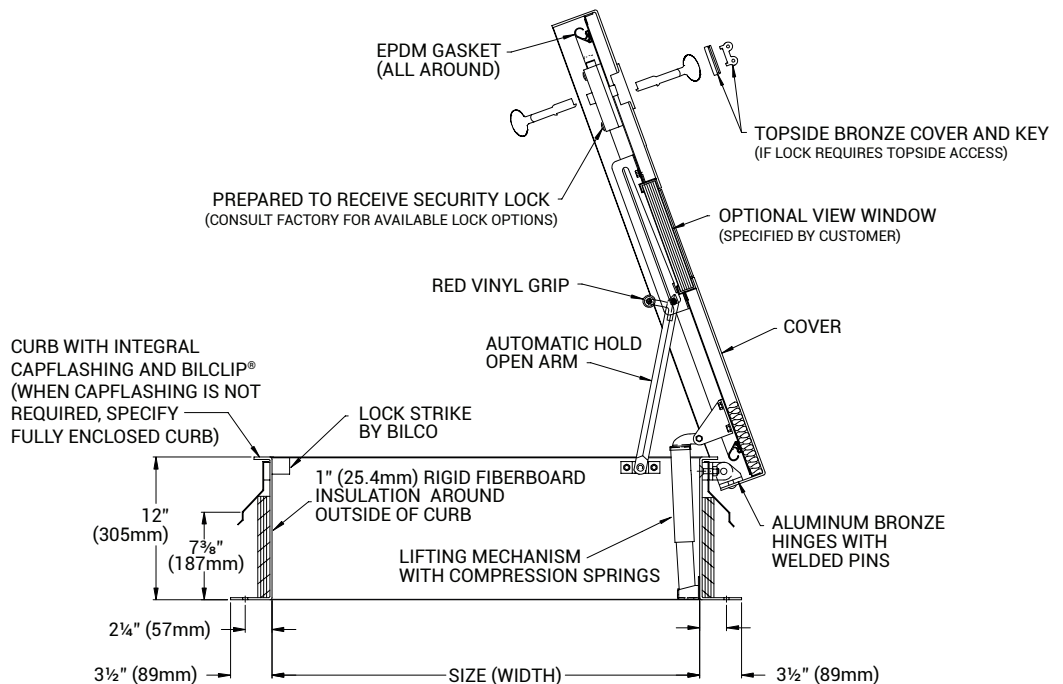

PROJECT DATA

Custom Sizes Available - Fast!

PROJECT NAME :	QTY	W	H	OPTIONS
ARCHITECT :				
DEALER :				
CONTRACTOR :				
LOCATION :	SPECIAL INSTRUCTIONS :			
DATE :				
TAGGING INSTRUCTIONS :	SUBMITTAL APPROVAL : (signature or stamp)			

Scan or Click



To view Pricing and Additional Product Info.

TELEPHONE:
1-800-483-0823
 FAX:
1-888-828-6021

385 WILSON STREET EAST,
 SUITE 302
 ANCASTER, ON, L9G 2C1
 CANADA



WEBSITE:
www.BestAccessDoors.ca
 E-MAIL:
info@bestaccessdoors.ca