



Quality Access Doors- FAST!

SUBMITTAL/TECHNICAL DATA SHEET

DESCRIPTION

The access panel consists of a welded aluminum frame and is available with 1/2" (12.7 mm) or 5/8" (15.9 mm) drywall inlay and two latches.

Both an outer and an inner frame assembly consists of high grade aluminum which is bonded with a special welding process.

For sizes 12" x 12" (305 x 305 mm) and up the access panels are equipped with a safety system to prevent accidental opening. This safety system must be reattached if the hatch is removed.

The reveal of 1/8 of an inch (3 mm) is visible between the outer frame and door hatch. The concealed snap locks open the access panel when pressure is applied to the spring loaded latch side.

This access panel is designed for tiling applications.

DIMENSIONS

The access panel is aligned to the grid dimension of the tiles. Information on the dimensions of the tiles and joint gaps is required from which dimensions and can be ascertained.

Dimensions D and E remain constant. Dimension C corresponds to the respective drywall thicknesses.

ADVANTAGE

- Superior engineering & innovative design
- Fast delivery
- Quick and easy installation
- Solid aluminum frame
- Lateral opening
- Available in green board and cement board

OPTIONS

- Screwdriver operated cam latch
- Round Cylinder Lock with Key
- Hex Head Cam Latch
- Pinned Hex Head Cam Latch

For a complete list of options visit www.BestAccessDoors.ca



SKU: **BAC-IVT**

DRYWALL ACCESS PANEL FOR TILING

■ DIMENSIONS AND APPEARANCE

>> [CLICK TO VIEW ADDITIONAL DETAILS AND PRICING <<](#)

These are custom sizes, manufactured exactly according to customer specifications.

- For "TILING THE DOOR LEAF": The aluminum profile is flush with the board. The tiles are placed upon the profile.

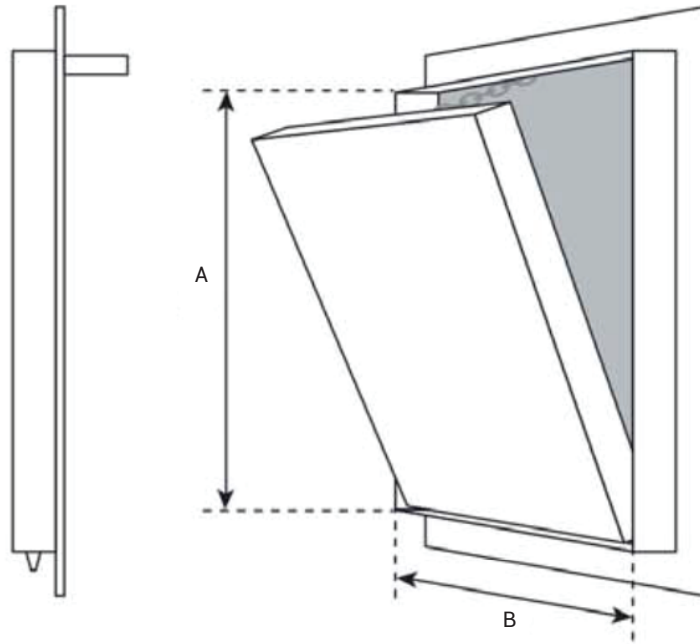

Left picture: Closed side view, with latches.

* Rough opening is door size +3/8" (9mm)

All standard sizes are available in 1/2" (12.7 mm) or 5/8" (15.9 mm) drywall. Dimensions A+B are exactly produced to customer's specifications.

■ PROJECT DATA

Custom Sizes Available - Fast!

PROJECT NAME :	QTY	W	H	OPTIONS
ARCHITECT :				
DEALER :				
CONTRACTOR :				
LOCATION :	SPECIAL INSTRUCTIONS :			
DATE :				
TAGGING INSTRUCTIONS :	SUBMITTAL APPROVAL : (signature or stamp)			

Scan or Click



To view Pricing and Additional Product Info.

TELEPHONE:
1-800-483-0823
FAX:
1-888-828-6021



385 WILSON STREET EAST,
SUITE 302
ANCASTER, ON, L9G 2C1
CANADA



WEBSITE:
www.BestAccessDoors.ca
E-MAIL:
info@bestaccessdoors.ca