



Quality Access Doors- FAST!

SUBMITTAL/TECHNICAL DATA SHEET

APPLICATION

Designed for interior and exterior applications that require an access opening that will blend in with the surrounding floor material

FEATURES

- Recessed 1" to accommodate ceramic tile/concrete flooring
- Door panel is equipped with a flush aluminum drop handle and an automatic hold open arm

SPECIFICATIONS

MATERIAL: Aluminum door and frame; stainless steel hinges and hardware

DOOR: 1/4" smooth aluminum plate reinforced for live load of 300 lb/sq. ft. Extruded edging is welded to door panel, providing a 1" recess

FRAME: Channel frame fabricated from aluminum extrusion with 1 1/2" drainage coupling and integral 1" anchor flange

HINGE: Stainless steel continuous piano hinge

OPENING DEVICE: Automatic Hold-Open Arm with red vinyl grip allows door panel to open to 90 degrees, locking door in open position, and allowing for easy control when closing door panel. Stainless Steel Open Compression Springs provide lift assist. Available with electrical actuators, operated by wall mounted push button switch, and remote control

STANDARD LATCH: Stainless steel slam lock with a fixed inside handle, removable outside handle, and removable threaded plug

FINISH: Mill finish with bituminous coating applied to exterior of frame

SKU: **BAC-HFRC-1**

HINGED FLOOR HATCH

RECESSED 1" FOR CONCRETE



DIMENSIONS AND APPEARANCE

>> CLICK TO VIEW ADDITIONAL DETAILS AND PRICING <<

DOOR SIZE W x H INCHES (MM)	WEIGHT	
	LBS	KG
24 x 24 (610 x 610)	70	32
24 x 30 (610 x 762)	80	37
24 x 36 (610 x 914)	90	41
30 x 30 (762 x 762)	110	50
30 x 36 (762 x 914)	100	45
36 x 36 (914 x 914)	115	52
42 x 42 (1067 x 1067)	140	64
*48 x 48 (1220 x 1220)	195	89
*48 x 72 (1220 x 1829)	265	120
*60 x 60 (1524 x 1524)	275	125

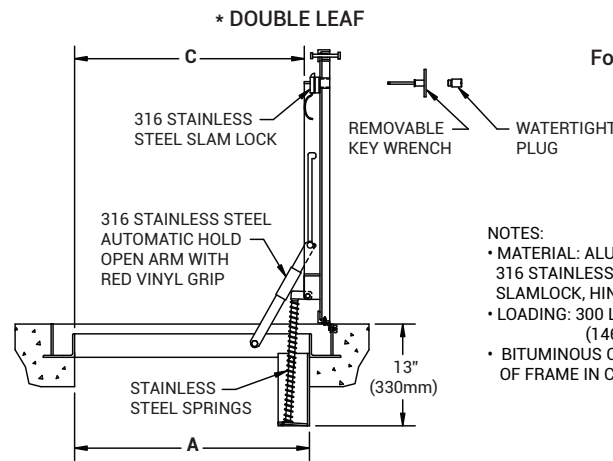
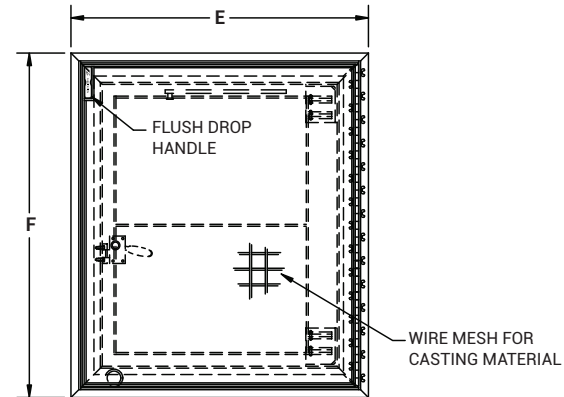

For detailed specifications see submittal sheet

MANUFACTURED BY ACUDOR

- NOTES:**
- MATERIAL: ALUMINUM WITH SPRINGS, 316 STAINLESS STEEL NUTS & BOLTS, SLAMLOCK, HINGES AND HOLD OPEN ARM.
 - LOADING: 300 LBS. PER SQ. FOOT (1464 KG. PER SQ. M)
 - BITUMINOUS COATING IS APPLIED TO AREA OF FRAME IN CONTACT WITH CONCRETE.

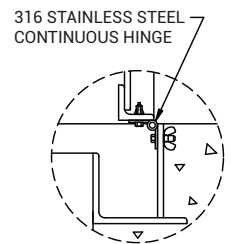

For a complete list of options visit www.BestAccessDoors.ca

PROJECT DATA

Custom Sizes Available - Fast!

PROJECT NAME :	QTY	W	H	OPTIONS
ARCHITECT :				
DEALER :				
CONTRACTOR :				
LOCATION :	SPECIAL INSTRUCTIONS :			
DATE :				
TAGGING INSTRUCTIONS :	SUBMITTAL APPROVAL : (signature or stamp)			

Scan or Click



To view Pricing and Additional Product Info.

TELEPHONE:
1-800-483-0823

FAX:
1-888-828-6021

385 WILSON STREET EAST,
SUITE 302
ANCASTER, ON, L9G 2C1
CANADA



WEBSITE:
www.BestAccessDoors.ca

E-MAIL:
info@bestaccessdoors.ca

BAC-HFRC-1 HINGED FLOOR HATCH RECESSED 1" FOR CONCRETE - SINGLE LEAF

NOMINAL DOOR SIZE	FRAME OPENING		CLEAR OPENING		OVERALL SIZE		WEIGHT
in. (mm)	A in. (mm)	B in. (mm)	C in. (mm)	D in. (mm)	E in. (mm)	F in. (mm)	LBS. (KG)
24 x 24 (610 x 610)	24 (610)	24 (610)	23 (584)	24 (610)	32 (813)	32 (813)	70 (32)
24 x 30 (610 x 762)	24 (610)	30 (762)	23 (584)	30 (762)	32 (813)	38 (965)	80 (37)
24 x 36 (610 x 914)	24 (610)	36 (914)	23 (584)	36 (914)	32 (813)	44 (1118)	90 (41)
30 x 30 (762 x 762)	30 (762)	30 (762)	28 (711)	30 (762)	38 (965)	38 (965)	110 (50)
30 x 36 (762 x 914)	30 (762)	36 (762)	28 (711)	36 (762)	38 (965)	44 (1118)	100 (45)
36 x 36 (914 x 914)	36 (914)	36 (762)	34 (864)	36 (762)	44 (1118)	44 (1118)	115 (52)
42 x 42 (1067 x 1067)	42 (1067)	42 (1067)	40 (1016)	42 (1067)	50 (1270)	50 (1270)	140 (64)

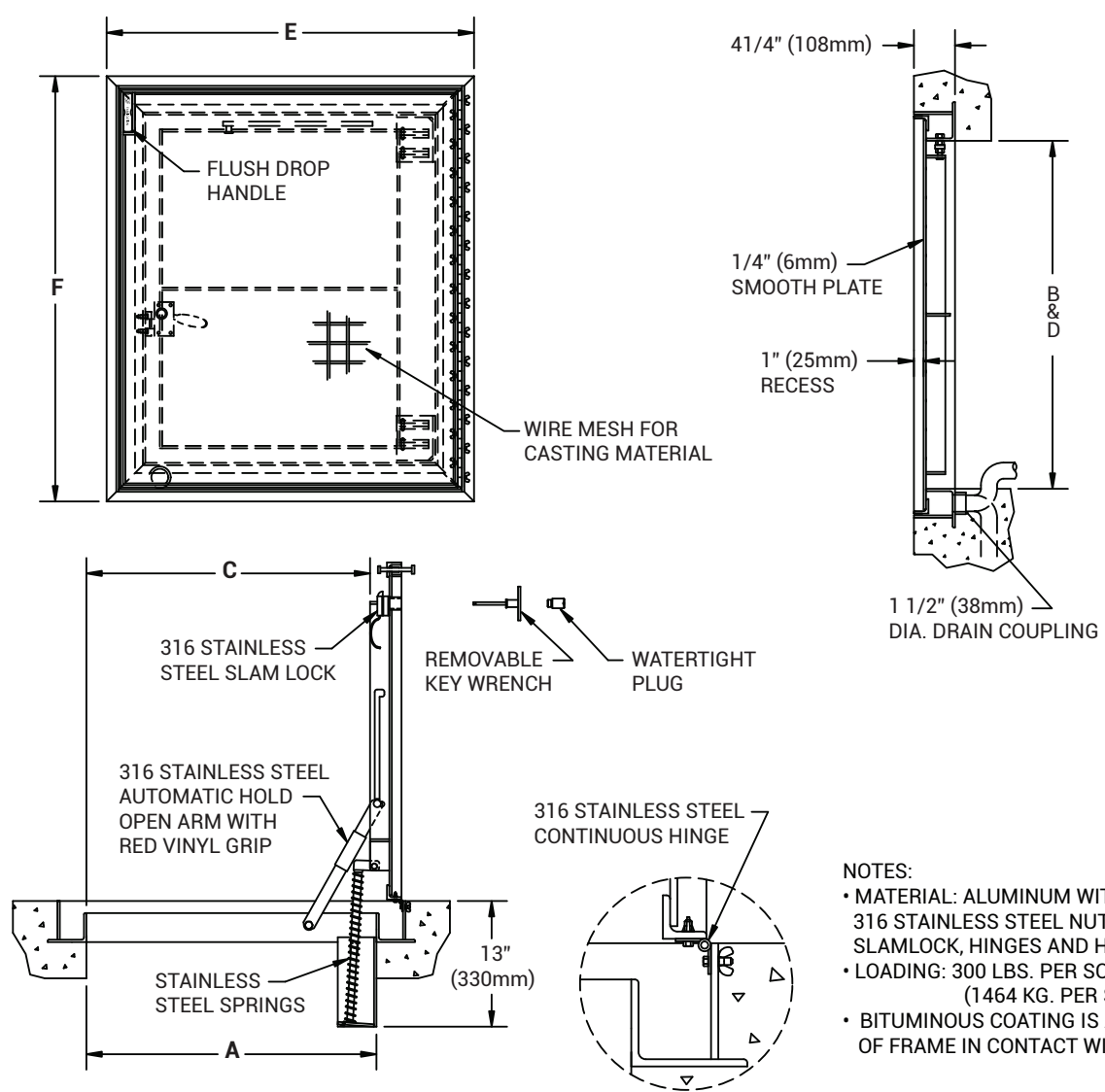

- NOTES:
- MATERIAL: ALUMINUM WITH SPRINGS, 316 STAINLESS STEEL NUTS & BOLTS, SLAMLOCK, HINGES AND HOLD OPEN ARM.
 - LOADING: 300 LBS. PER SQ. FOOT (1464 KG. PER SQ. M)
 - BITUMINOUS COATING IS APPLIED TO AREA OF FRAME IN CONTACT WITH CONCRETE.

BAC-HFRC-1 HINGED FLOOR HATCH RECESSED 1" FOR CONCRETE - DOUBLE LEAF

NOMINAL DOOR SIZE	FRAME OPENING		CLEAR OPENING		OVERALL SIZE		WEIGHT
in. (mm)	A in. (mm)	B in. (mm)	C in. (mm)	D in. (mm)	E in. (mm)	F in. (mm)	LBS. (KG)
48 x 48 (1220 x 1220)	48 (1220)	48 (1220)	47 (1193)	48 (1220)	56 (1422)	56 (1422)	195 (89)
48 x 72 (1220 x 1829)	48 (1220)	72 (1828)	47 (1193)	72 (1828)	56 (1422)	80 (2032)	265 (120)
60 x 60 (1524 x 1524)	60 (1524)	60 (1524)	59 (1498)	60 (1524)	68 (1727)	68 (1727)	275 (125)

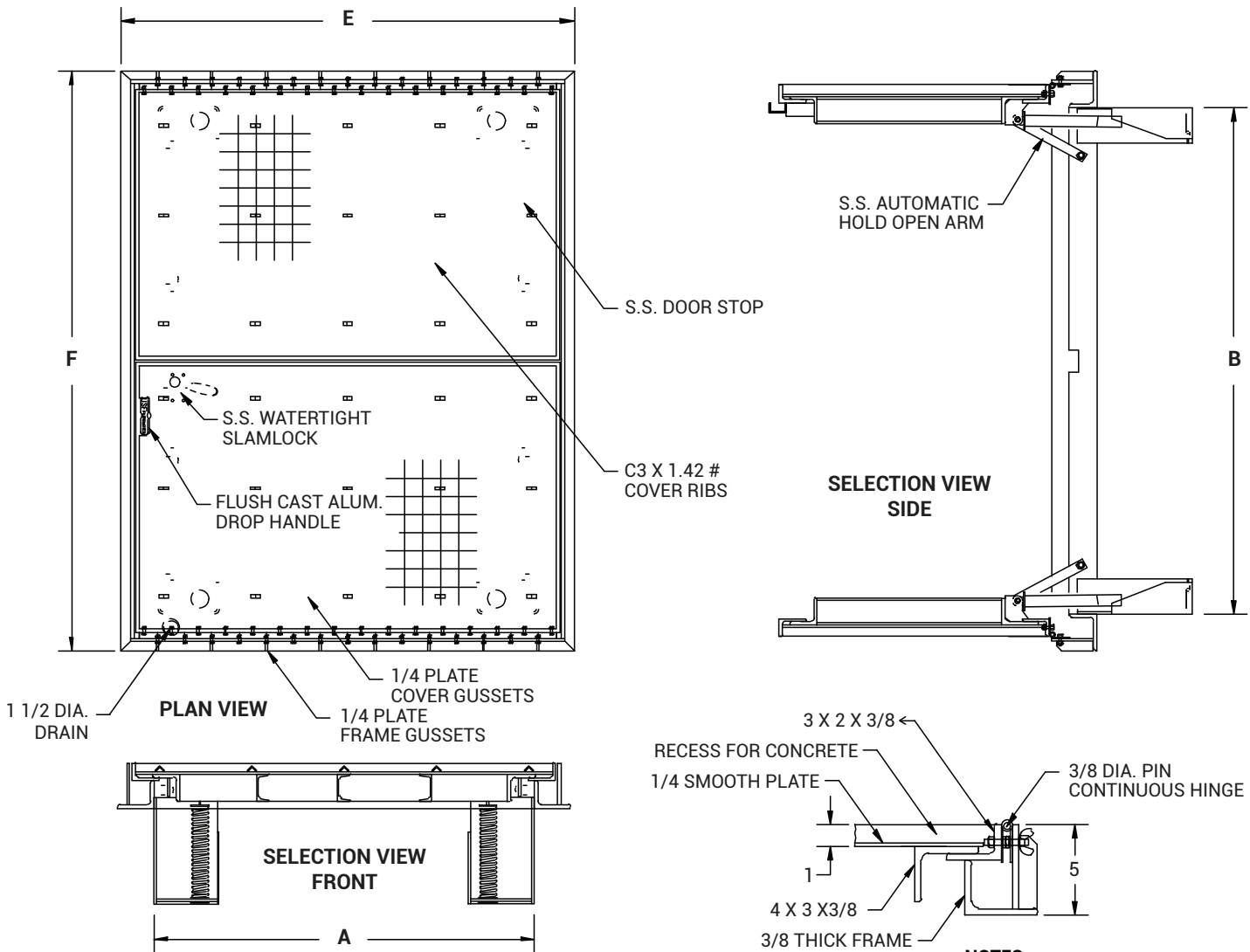

- NOTES:**
- MATERIAL: ALUMINUM
 - LOADING: 300 LBS. PER SQ. FT.
 - 316 STAINLESS STEEL BOLTS HINGES AND HOLD OPEN ARM

MANUFACTURED BY ACUDOR