



Quality Access Doors- FAST!

SUBMITTAL/TECHNICAL DATA SHEET

SKU: **BAC-ASV-DL**

SMOKE VENT DOUBLE LEAF ALUMINUM



APPLICATION

Smoke Vents are designed to provide an economical solution for fire ventilation. These UL-Listed, automatic Smoke Vents provide invaluable assistance to firefighters by evacuating deadly smoke, heat, and gases from a burning building

FEATURES

- 1/8" Aluminum
- 12" high insulated curb
- High performance gas springs
- Inside and Outside manual release
- UL Listed Fusible or McCabe Resettable Links

OPTIONAL FEATURES

- Curb mount or Metal Building Flange
- Double-Dome Co-Polyester lids for daylighting
- Louvered curb for ventilation

SPECIFICATIONS

COVER: Double-skin construction ("in box type design") with 1" cellulose insulation and a continuous EPDM foam weather/draft seal gasket that is attached to the inside of cover to provide a flush, tight fit. Designed to support a live load of 40lbs./sq. ft., the cover is 11 gauge aluminum with a 20 gauge aluminum inside liner.

CURB: 1/8" Aluminum with 1" thick fiberboard roof insulation at curb exterior. Curb is 12" high, with 3.375" wide bottom flange and pre-drilled mounting holes.

HINGE: Heavy duty galvanized steel / aluminum pintle hinges with 3/8" pin

OPENING: Gas spring operators allow cover to open and close with ease. Inside and outside release allows for manual lid operation.

DOOR LATCH: Self latching Slam Latch. Supplied standard with 165° UL Listed Fusible Link. Resettable McCabe link available.

FINISH: Aluminum: Mill Finish

■ DIMENSIONS AND APPEARANCE

>> [CLICK TO VIEW ADDITIONAL DETAILS AND PRICING <<](#)

MODEL	CURB ID L&W INCHES (MM)	WEIGHT	
		LBS	KG
SVA4848	48 x 48 (1219 x 1219)	105	48
SVA4872	48 x 72 (1219 x 1219)	130	59
SVA4890	48 x 90 (1219 x 1219)	135	61
SVA4896	48 x 96 (1219 x 1219)	140	64
SVA6060	60 x 60 (1219 x 1219)	130	59
SVA6072	60 x 72 (1219 x 1219)	135	61
SVA6090	60 x 90 (1219 x 1219)	165	75
SVA6096	60 x 96 (1219 x 1219)	170	77

For detailed specifications see submittal sheet

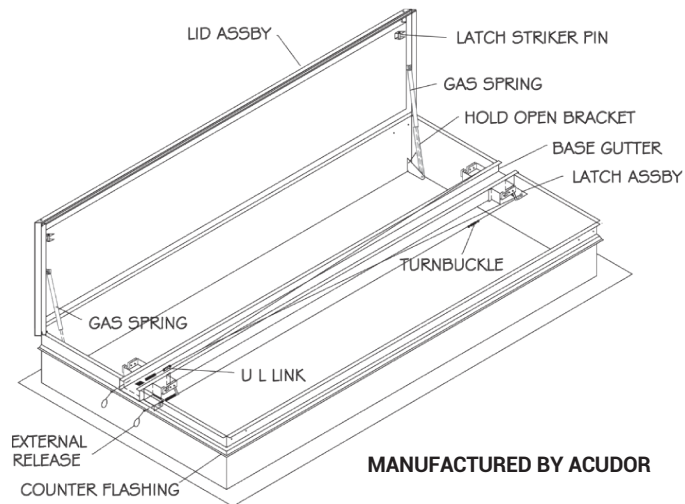

MANUFACTURED BY ACUDOR

For a complete list of options visit www.BestAccessDoors.ca

■ PROJECT DATA

Custom Sizes Available - Fast!

Scan or Click



To view Pricing and Additional Product Info.

PROJECT NAME :	QTY	W	H	OPTIONS
ARCHITECT :				
DEALER :				
CONTRACTOR :				
LOCATION :	SPECIAL INSTRUCTIONS :			
DATE :				
TAGGING INSTRUCTIONS :	SUBMITTAL APPROVAL : (signature or stamp)			

TELEPHONE:
1-800-483-0823

FAX:
1-888-828-6021



385 WILSON STREET EAST,
SUITE 302
ANCASTER, ON, L9G 2C1
CANADA



WEBSITE:
www.BestAccessDoors.ca

E-MAIL:
info@bestaccessdoors.ca

BAC-ASV-DL

SMOKE VENT DOUBLE LEAF ALUMINUM

QTY	OPENING WIDTH 'W'	OPENING LENGTH 'L'	QTY	OPENING WIDTH 'W'	OPENING LENGTH 'L'
	48" (1219mm)	48" (1219mm)		60" (1524mm)	60" (1524mm)
	48" (1219mm)	72" (1829mm)		60" (1524mm)	72" (1829mm)
	48" (1219mm)	90" (2286mm)		60" (1524mm)	90" (2286mm)
	48" (1219mm)	96" (2286mm)		60" (1524mm)	96" (2438mm)

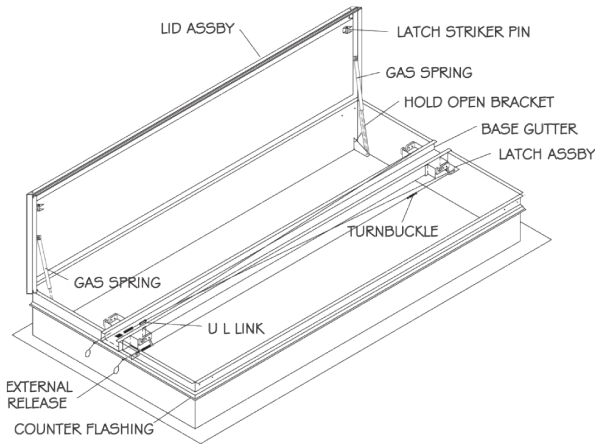

SPECIFICATIONS:

- Fully Welded & Assembled Aluminum Curb
- 4" x 4" x 3/16" Galvanized Steel OSHA Compliant Safety Screen Option
- Base options include self flashing, curb mount and metal building
- 1" Rigid Insulation R7.2
- Full perimeter EPDM bulb gaskets
- Lids open against a 10 PSF live load
- Lid uplift rating 30 PSF
- Hinges and latches 12 gauge
- Latches rated for 90 PSF uplift
- UL listed fusible or McCabe resettable links
- Inside and outside manual releases
- High performance gas springs with hold open

