



Quality Access Doors- FAST!

SUBMITTAL/TECHNICAL DATA SHEET

APPLICATION

- This recessed access door is ideal for use on tiled and marbled walls
- Door accepts tiles/marbles with grout gaps, harmoniously blending with surroundings
- Installed door remains invisible ensuring architecturally pleasing appearance

FEATURES

- Zinc coated steel provides superior corrosion resistance
- Concealed heavy duty hinge
- Recessed door accepts Tiles and Marbles of varied thicknesses
- Concealed Latch

SPECIFICATIONS

MATERIAL: 16 Ga Satin Coat Steel
DOOR: 16 Ga, 3/4" recessed tray to accept 5/8" MDF and glue by others
FRAME: 16 Ga, press bent for strength and rigidity
HINGE: Continuous concealed piano hinge
STANDARD LOCK: Cam Latch
OPTIONAL LOCK: Touch Latch, Magnetic Lock
FINISH: Powder coated RAL 9016

SKU: **BAG-TD-5025**

SPECIALTY ACCESS DOOR

RECESSED ACCESS DOOR FOR TILE AND MARBLE



DIMENSIONS AND APPEARANCE

>> CLICK TO VIEW ADDITIONAL DETAILS AND PRICING <<

DOOR SIZE W x H INCHES (MM)	LATCHES	WEIGHT	
		LBS	KG
12 x 12 (300 x 300)	1	10.0	4.5
14 x 14 (350 x 350)	1	13.0	5.9
16 x 16 (400 x 400)	1	15.0	6.8
18 x 18 (450 x 450)	1	18.0	8.2
24 x 24 (610 x 610)	1	25.0	11.3
24 x 36 (610 x 914)	2	34.0	15.4

For detailed specifications see submittal sheet

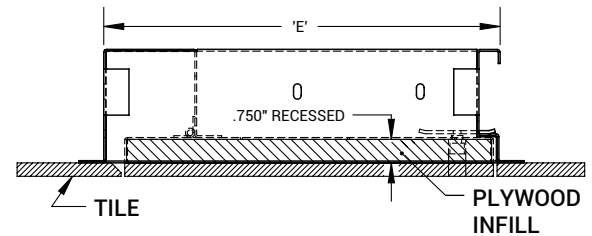

MANUFACTURED BY ACUDOR

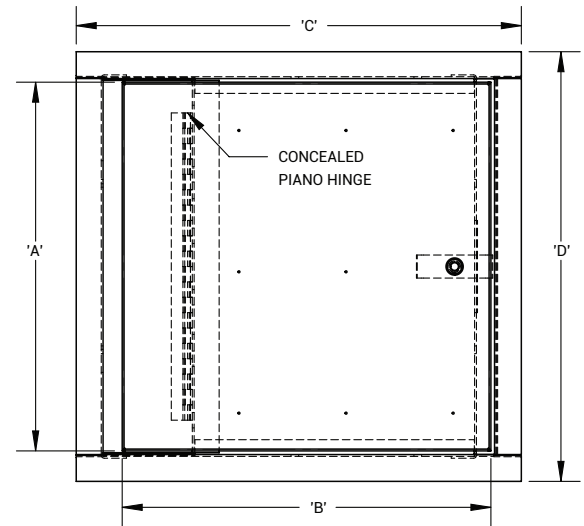
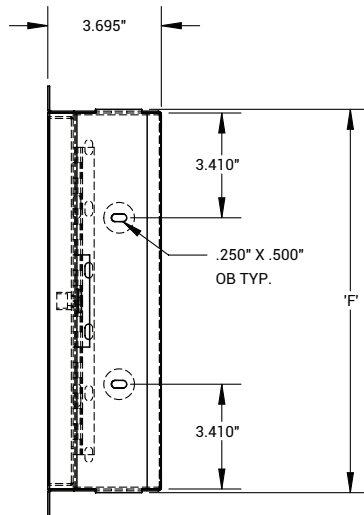

For a complete list of options visit www.BestAccessDoors.ca

PROJECT DATA

Custom Sizes Available - Fast!

Scan or Click



To view Pricing and Additional Product Info.

PROJECT NAME :	QTY	W	H	OPTIONS
ARCHITECT :				
DEALER :				
CONTRACTOR :				
LOCATION :	SPECIAL INSTRUCTIONS :			
DATE :				
TAGGING INSTRUCTIONS :	SUBMITTAL APPROVAL : (signature or stamp)			

TELEPHONE:
1-800-483-0823
FAX:
1-888-828-6021

385 WILSON STREET EAST,
SUITE 302
ANCASTER, ON, L9G 2C1
CANADA



WEBSITE:
www.BestAccessDoors.ca
E-MAIL:
info@bestaccessdoors.ca

BAC-TD-5025

RECESSED DOOR FOR TILE

NOMINAL DOOR SIZE	A	B	C	D	E	F	LATCHES
12 x 12	12	12	14.486	12.983	12.901	12.476	1
14 x 14	14	14	16.486	15.983	14.901	14.476	1
16 x 16	16	16	18.486	17.983	16.901	16.476	1
18 x 18	18	18	20.486	19.983	18.901	18.476	1
24 x 24	24	24	26.486	25.983	24.901	24.476	1
24 x 36	24	36	38.486	25.983	24.901	36.476	2

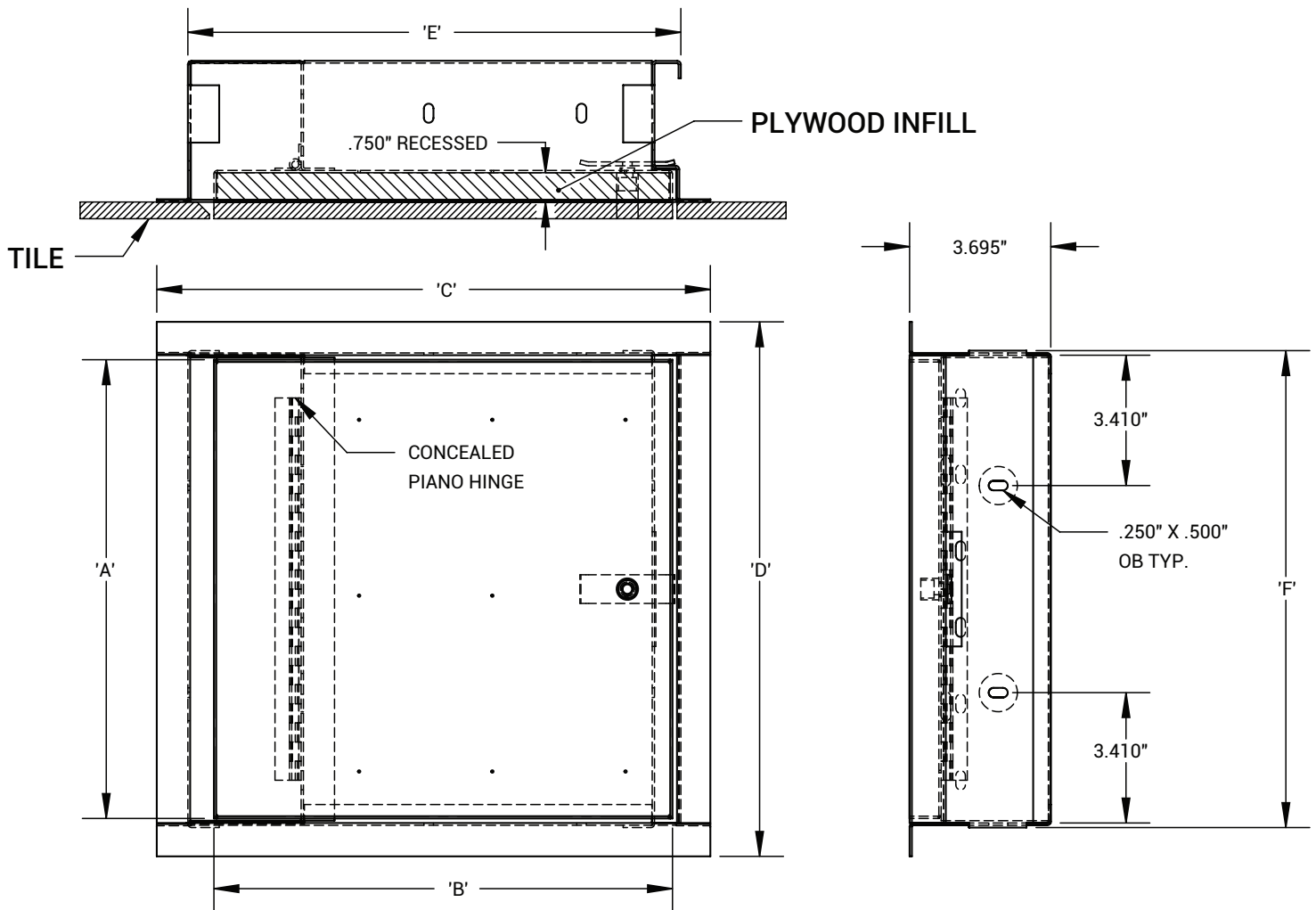

MANUFACTURED BY ACUDOR