



Quality Access Doors- FAST!

# SUBMITTAL/TECHNICAL DATA SHEET

## STANDARD OPTIONS

- MATERIAL:**  
16 Gauge cold rolled steel
- HINGE:**  
Continuous piano hinge
- LOCK / LATCH:**  
Self latching tool-key operated slam latch and/or ring operated slam latch, both included
- PLY:**  
2 3/4" Steel lath flange
- INSIDE PANEL RELEASE:**  
Standard on all doors over 12" x 12"
- AUTOMATIC PANEL CLOSER:**  
Standard on all doors
- FINISH:**  
High quality white powder coat primer
- PACKAGING:**  
Individually wrapped, 1 per box

## OPTIONS AVAILABLE

- LOCK / LATCH:**
- Key operated cylinder cam latch
  - Handle operated slam latch
  - Mortise preparation for cylinder (cylinder optional)
  - Hex head slam latch
  - Mortise deadbolt lock
- MATERIAL:**  
Stainless steel #4 (brushed finish)
- MASONRY ANCHOR:**  
Available on all sizes

Fire Rating information on Page 2

For a complete list of options visit [www.BestAccessDoors.ca](http://www.BestAccessDoors.ca)

Scan or Click



To view Pricing and Additional Product Info.

LEED READY: THIS PRODUCT CONTRIBUTES TO LEED® CREDITS

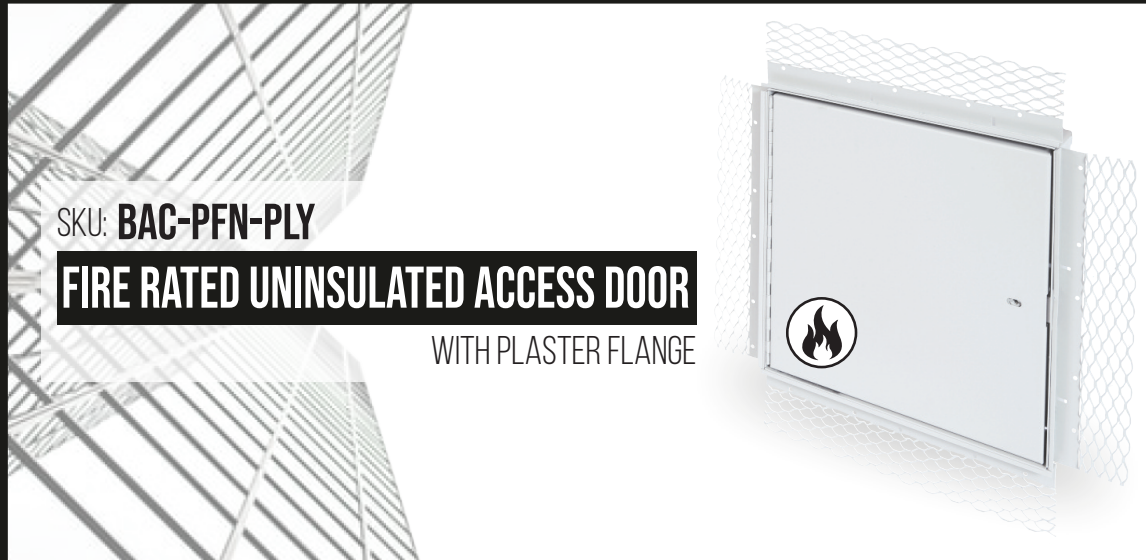

SKU: **BAG-PFN-PLY**

## FIRE RATED UNINSULATED ACCESS DOOR

WITH PLASTER FLANGE

## INSTALLATION

>> CLICK TO VIEW ADDITIONAL DETAILS AND PRICING <<

[ 2 HOUR WALL APPLICATION ]

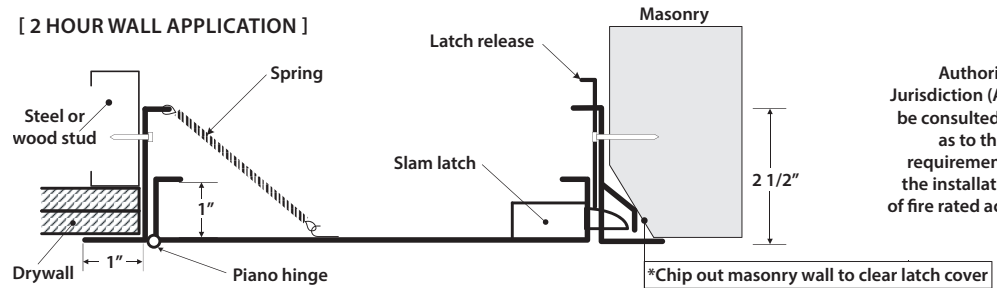

Authorities Having Jurisdiction (AHJ) should be consulted in all cases as to the particular requirements covering the installation and use of fire rated access doors.

## DIMENSIONS AND APPEARANCE

STANDARD SIZES:

DOOR SIZE W x H inches (MM)	NUMBER OF LOCKS	WEIGHT LBS KG
8 x 8 (203 x 203)	1	5 2.3
10 x 10 (254 x 254)	1	7 3.2
12 x 12 (304 x 304)	1	8 3.6
14 x 14 (355 x 355)	1	10 4.5
16 x 16 (406 x 406)	1	12 5.5
18 x 18 (457 x 457)	1	14 6.4
22 x 22 (558 x 558)	1	18 8.2
22 x 30 (558 x 762)	1	22 10
22 x 36 (558 x 914)	2	27 12.2
24 x 24 (609 x 609)	1	22 10
24 x 36 (609 x 914)	2	29 13.2
30 x 30 (762 x 762)	1	30 13.6
32 x 32 (812 x 812)	2	33 15
36 x 36 (914 x 914)	2	39 17.7

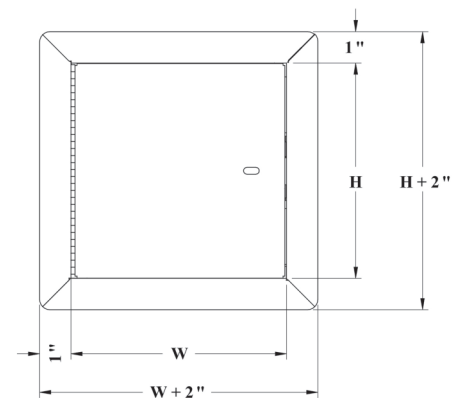

ROUGH WALL OPENING IS DOOR SIZE + 1/4" OR + 6MM

## PROJECT DATA

Custom Sizes Available - Fast!

PROJECT NAME :	QTY	W	H	OPTIONS
ARCHITECT :				
DEALER :				
CONTRACTOR :				
LOCATION :	SPECIAL INSTRUCTIONS :			
DATE :				
TAGGING INSTRUCTIONS :	SUBMITTAL APPROVAL : (signature or stamp)			

TELEPHONE:  
1-800-483-0823

FAX:  
1-888-828-6021

385 WILSON STREET EAST,  
SUITE 302  
ANCASTER, ON, L9G 2C1  
CANADA

WEBSITE:  
[www.BestAccessDoors.ca](http://www.BestAccessDoors.ca)

E-MAIL:  
[info@BestAccessDoors.ca](mailto:info@BestAccessDoors.ca)



## ■ FIRE RATING

### FOR VERTICAL WALL ASSEMBLIES ONLY:

CERTIFIED TO STANDARDS: UBC 7-2 (1997), UL 10B (1997), UL 10B (2009), NFPA 252 (2003), NFPA 252 (2008), NFPA 252 (2012), CAN/ULC S104 (R1985), CAN/ULC S104 (2010).

RATING ACHIEVED: 1-1/2 hours, neutral/negative pressure

MAXIMUM SIZE: 36" wide x 36" high (914 mm x 914 mm). Maximum area of 1296 in<sup>2</sup>.

Tolerance on height and width limitation is ± 3" (76 mm) as long as the area does not exceed 1296 in<sup>2</sup>

TEMPERATURE RISE: No rating achieved.

## ■ INSTALLATION: WALLS AND CEILINGS

[ 2 HOUR WALL APPLICATION ]

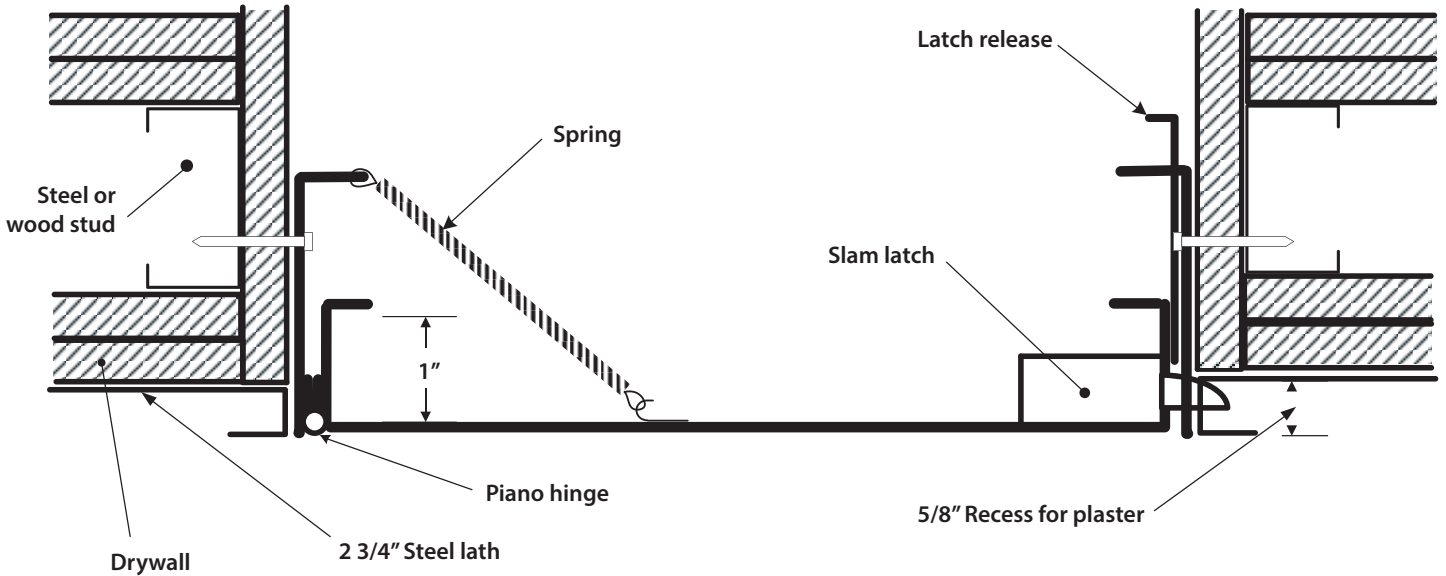

Authorities Having Jurisdiction (AHJ) should be consulted in all cases as to the particular requirements covering the installation and use of fire rated access doors.



TELEPHONE:  
1-800-483-0823  
FAX:  
1-888-828-6021



385 WILSON STREET EAST,  
SUITE 302  
ANCASTER, ON, L9G 2C1  
CANADA



WEBSITE:  
[www.BestAccessDoors.ca](http://www.BestAccessDoors.ca)  
E-MAIL:  
[info@BestAccessDoors.ca](mailto:info@BestAccessDoors.ca)