



Quality Access Doors- FAST!

SUBMITTAL/TECHNICAL DATA SHEET

DESCRIPTION

The access panel consists of a welded aluminum frame and is available with 1/2" (12.7 mm) or 5/8" (15.9 mm) inlaid drywall and two latches. Both an outer and an inner frame assembly consists of high grade aluminum which is bonded with a special welding process. For sizes 12" x 12" (305 x 305 mm) and up the access panels are equipped with a safety system to prevent accidental opening. This safety system must be reattached if the hatch is removed.

The reveal of 1/16 of an inch (1.59 mm) is visible between the outer frame and door hatch. The concealed snap locks open the access panel when pressure is applied to the spring loaded latch side.

This access panel is designed to be recessed into concrete wall systems. This panel comes with predrilled holes for easy installation.

ADVANTAGES

- Superior engineering & innovative design
- Fast delivery
- Quick and easy installation
- Solid aluminum frame
- Flush installation in ceilings and walls
- Available in moisture / mildew resistant green board and cement board

For a complete list of options visit www.BestAccessDoors.ca

SKU: **BAG-MWS**

DRYWALL ACCESS PANEL

FOR MASONRY APPLICATIONS



DIMENSIONS AND APPEARANCE

>> CLICK TO VIEW ADDITIONAL DETAILS AND PRICING <<

OPTIONS:

SD	- Screwdriver operated cam latch
FS	- Screwdriver operated four-square cam latch
Z	- Round Cylinder Lock with Key
M	- Mortise Cylinder Lock Preparation
H	- Hex Head Cam Latch
P	- Pinned Hex Head Cam Latch

Drywall insert with screws on larger sizes than 24" x 24" (610 mm x 610 mm).

Customized sizes can be produced in every dimension upon request.

Rough opening is door size + 3/4" (9 mm)

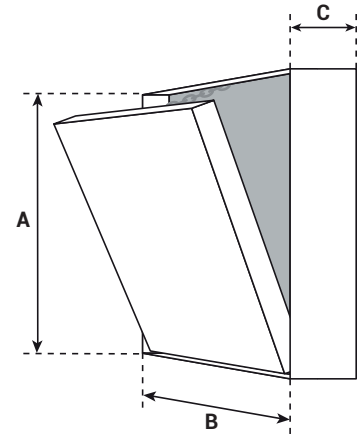

All standard sizes are available in 1/2" (12.7 mm) or 5/8" (15.9 mm) drywall.

Side opening non-removable



PROJECT DATA

Custom Sizes Available - Fast!

Scan or Click



To view Pricing and Additional Product Info.

PROJECT NAME :	QTY	W	H	OPTIONS
ARCHITECT :				
DEALER :				
CONTRACTOR :				
LOCATION :	SPECIAL INSTRUCTIONS :			
DATE :	SUBMITTAL APPROVAL : (signature or stamp)			
TAGGING INSTRUCTIONS :				

TELEPHONE:
1-800-483-0823

FAX:
1-888-828-6021



385 WILSON STREET EAST,
SUITE 302
ANCASTER, ON, L9G 2C1
CANADA



WEBSITE:
www.BestAccessDoors.ca

E-MAIL:
info@bestaccessdoors.ca