



Quality Access Doors- FAST!

# SUBMITTAL/TECHNICAL DATA SHEET

## DESCRIPTION

The access panel consists of a welded aluminum frame and is available with 1/2" (12.7 mm) or 5/8" (15.9 mm) drywall inlay and two latches. Both an outer and an inner frame assembly consists of high grade aluminum which is bonded with a special welding process. For sizes 12" x 12" (305 x 305 mm) and up the access panels are equipped with a safety system to prevent accidental opening. This safety system must be reattached if the hatch is removed.

The reveal of 1/16 of an inch (1.59 mm) is visible between the outer frame and door hatch. The concealed snap locks open the access panel when pressure is applied to the spring loaded latch side. This access panel is designed to be recessed into concrete wall systems. This panel comes with predrilled holes for easy installation.

## ADVANTAGE

- Superior engineering & innovative design
- Fast delivery
- Quick and easy installation
- Solid aluminum frame
- Flush installation in walls
- Available in moisture resistant, mildew resistant and cement board

## CUSTOMIZED SOLUTIONS

Customized sizes can be produced in every dimension upon request.

SKU: **BAG-MW**

## DRYWALL INLAY PANEL

FOR MASONRY APPLICATIONS



## DIMENSIONS AND APPEARANCE

>> CLICK TO VIEW ADDITIONAL DETAILS AND PRICING <<

### Standard Dimensions with 1/2" Drywall Inlay

System MWS	A(in)	A(mm)	B(in)	B(mm)	C(in)	C(mm)
MW203203G127	8	203	8	203	2.362	60
MW305305G127	12	305	12	305	2.362	60
MW406406G127	16	406	16	406	2.362	60
MW457457G127	18	457	18	457	2.362	60
MW508508G127	20	508	20	508	2.362	60
MW610610G127	24	610	24	610	2.362	60

### Standard Dimensions with 5/8" Drywall Inlay

System MWS	A(in)	A(mm)	B(in)	B(mm)	C(in)	C(mm)
MW203203G159	8	203	8	203	2.362	60
MW305305G159	12	305	12	305	2.362	60
MW406406G159	16	406	16	406	2.362	60
MW457457G159	18	457	18	457	2.362	60
MW508508G159	20	508	20	508	2.362	60
MW610610G159	24	610	24	610	2.362	60

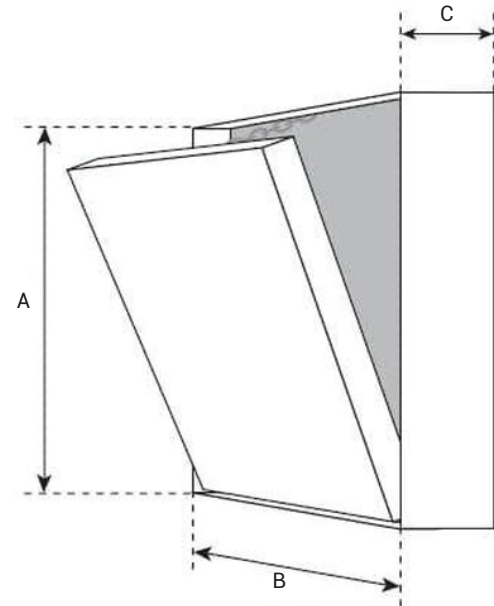

For a complete list of options visit [www.BestAccessDoors.ca](http://www.BestAccessDoors.ca)

## PROJECT DATA

Custom Sizes Available - Fast!

Scan or Click



PROJECT NAME :	QTY	W	H	OPTIONS
ARCHITECT :				
DEALER :				
CONTRACTOR :				
LOCATION :	SPECIAL INSTRUCTIONS :			
DATE :	SUBMITTAL APPROVAL : (signature or stamp)			
TAGGING INSTRUCTIONS :				

TELEPHONE:  
1-800-483-0823  
FAX:  
1-888-828-6021

385 WILSON STREET EAST,  
SUITE 302  
ANCASTER, ON, L9G 2C1  
CANADA



WEBSITE:  
[www.BestAccessDoors.ca](http://www.BestAccessDoors.ca)  
E-MAIL:  
[info@bestaccessdoors.ca](mailto:info@bestaccessdoors.ca)

To view Pricing and Additional Product Info.