



Quality Access Doors- FAST!

SUBMITTAL/TECHNICAL DATA SHEET

DESCRIPTION

The access panel consists of aluminium profiles, a hardie board insert and a round cylinder lock with key. Both, an outer and an inner frame of the access panel consist of four single frames, which are firmly connected due to a special welding process.

The access panel is equipped with a safety-system against accidental opening. In order to avoid accidents, this safety-system has to be secured after each opening. A joint gap of 1/8" (3mm) is visible between outer frame and door leaf, which is equipped with an innovative brush joint (air-tight and dust resistant) and, in addition, with a special joint (water resistant). Access panels for facades in the outer area are applicable for direct mounting into solid walls (without external wall insulation system) or for installation into a wall insulation system (foam sealed).

ADVANTAGE

- Economical solution
- Delivery at short notice on request
- Quick and easy assembly
- Solid aluminum frame
- Sophisticated solution
- Flush installation in facades

OPTIONS

- Screwdriver operated cam latch
- Screwdriver operated four-square cam latch
- Round cylinder lock with key
- Mortise cylinder lock preparation
- Hex head cam latch
- Pinned hex head cam latch

CUSTOMIZED SOLUTIONS

Customized sizes can be produced in every dimension upon request.

For a complete list of options visit www.BestAccessDoors.ca



SKU: **BAC-MPL**

DRYWALL ACCESS PANEL

FOR EXTERIOR FACADE

DIMENSIONS AND APPEARANCE

>> [CLICK TO VIEW ADDITIONAL DETAILS AND PRICING <<](#)

Standard Sizes:

System MPL	A(in)	A(mm)	B(in)	B(mm)
MPL203203	8	203	8	203
MPL305305	12	305	12	305
MPL406406	16	406	16	406
MPL508508	20	508	20	508
MPL610610	24	610	24	610

ALL STANDARD SIZES ARE AVAILABLE AT SHORT NOTICE.

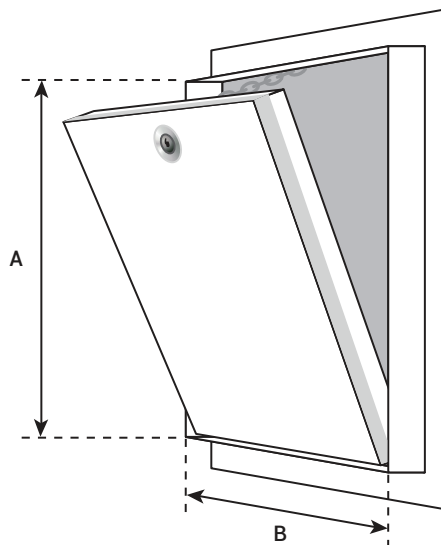

WITH 1/4" (6.35MM) HARDIE BOARD INLAY

ALSO AVAILABLE: SIDE-OPENING

PROJECT DATA

Custom Sizes Available - Fast!

Scan or Click



To view Pricing and Additional Product Info.

PROJECT NAME :	QTY	W	H	OPTIONS
ARCHITECT :				
DEALER :				
CONTRACTOR :				
LOCATION :	SPECIAL INSTRUCTIONS :			
DATE :	SUBMITTAL APPROVAL : (signature or stamp)			
TAGGING INSTRUCTIONS :				

TELEPHONE:
1-800-483-0823

FAX:
1-888-828-6021



385 WILSON STREET EAST,
SUITE 302
ANCASTER, ON, L9G 2C1
CANADA



WEBSITE:
www.BestAccessDoors.ca

E-MAIL:
info@bestaccessdoors.ca