



Quality Access Doors- FAST!

SUBMITTAL/TECHNICAL DATA SHEET

APPLICATION

An insulated, fire rated access door for inward opening in ceilings

FEATURES

- For fire rated ceilings, this door has been approved by Warnock Hersey International for 3 hours (max. size to 24" x 36")
- Insulated Door Panel
- Self-Closing
- Self-Latching
- Inside Latch Release

SPECIFICATIONS

MATERIAL: Steel or Stainless Steel

DOOR: 16 gauge, Flush to frame with reinforced edges filled with 2" thick fire insulation

MOUNTING FRAME: 16 gauge mounting frame, with trim 1" wide

HINGE: Concealed with coil spring for dampening

FIRE RATING: For Ceilings: Warnock Hersey International 3 hour rated in a non-combustible ceiling. 1 hour rated in a combustible ceiling. Max size: 24x 36

STANDARD LATCH: L Handle - operable from both sides

FINISH: Steel: 5 stage iron phosphate preparation with prime coat of white baked-on enamel.

Stainless Steel: Type 304 - #4 satin polish

For a complete list of options visit www.BestAccessDoors.ca



SKU: **BAG-FW-5050-UP**

FIRE RATED INSULATED

UPSWING DOOR FOR CEILINGS



DIMENSIONS AND APPEARANCE

>> CLICK TO VIEW ADDITIONAL DETAILS AND PRICING <<

DOOR SIZE W x H INCHES (MM)	LATCHES	WEIGHT	
		LBS	KG
22 x 36 (203 x 203)	2	35	15.9
22 x 30 (254 x 254)	2	34	15.4
24 x 24 (305 x 305)	1	28	12.7
24 x 36 (356 x 356)	2	38	18.1

Ceiling opening is W + 1/2" (12 mm)
For detailed specifications see submittal sheet

MANUFACTURED BY ACUDOR

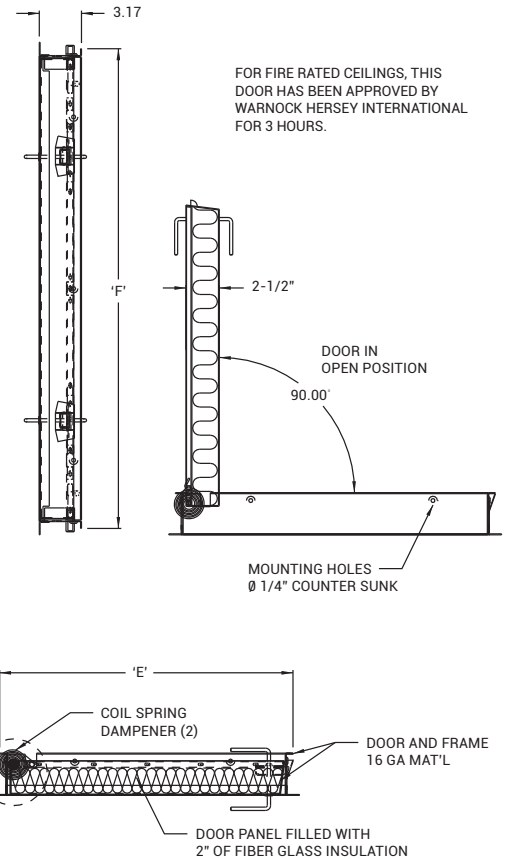
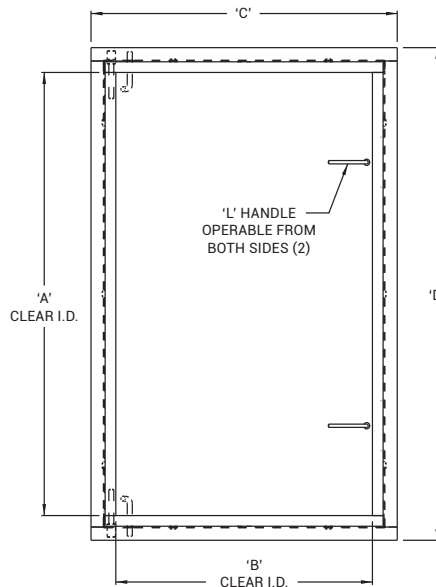

FOR FIRE RATED CEILINGS, THIS DOOR HAS BEEN APPROVED BY WARNOCK HERSEY INTERNATIONAL FOR 3 HOURS.

PROJECT DATA

Custom Sizes Available - Fast!

PROJECT NAME :	QTY	W	H	OPTIONS
ARCHITECT :				
DEALER :				
CONTRACTOR :				
LOCATION :	SPECIAL INSTRUCTIONS :			
DATE :				
TAGGING INSTRUCTIONS :	SUBMITTAL APPROVAL : (signature or stamp)			

Scan or Click



To view Pricing and Additional Product Info.

TELEPHONE:
1-800-483-0823

FAX:
1-888-828-6021

385 WILSON STREET EAST,
SUITE 302
ANCASTER, ON, L9G 2C1
CANADA



WEBSITE:
www.BestAccessDoors.ca

E-MAIL:
info@bestaccessdoors.ca

BAC-FW-5050-UP

CEILING FIRE RATED UPSWING

NOMINAL DOOR SIZE Inches (mm)	CEILING OPENING	'A' CLEAR I.D.	'B' CLEAR I.D.	'C'	'D'	'E'	'E'	LOCK
22 x 30 (559 x 762)	22.5 x 30.5 (559 x 762)	27.28 (692)	19.28 (490)	23.00 (270)	31.00 (787)	22.00 (559)	22.00 (559)	1
22 x 36 (559 x 914)	22.5 x 36.5 (559 x 914)	33.28 (845)	19.28 (490)	23.00 (321)	37.00 (940)	22.00 (559)	22.00 (559)	1
24 x 24 (610 x 610)	24.5 x 24.5 (610 x 610)	21.28 (540)	21.28 (540)	25.00 (371)	25.00 (635)	24.00 (610)	24.00 (610)	1
24 x 36 (610 x 914)	24.5 x 36.5 (610 x 914)	33.28 (845)	21.28 (540)	25.00 (422)	37.00 (940)	24.00 (610)	24.00 (610)	1

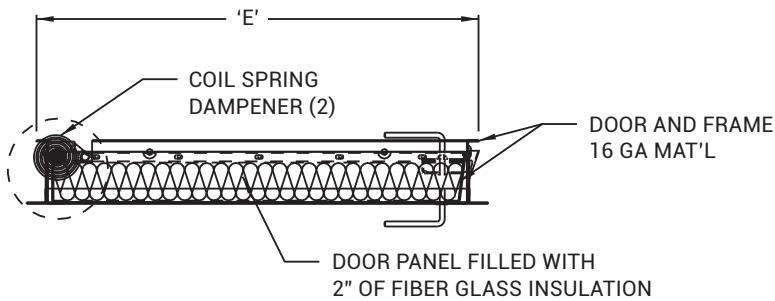

FOR FIRE RATED CEILING, THIS DOOR HAS BEEN APPROVED BY WARNOCK HERSEY INTERNATIONAL FOR 3 HOURS.

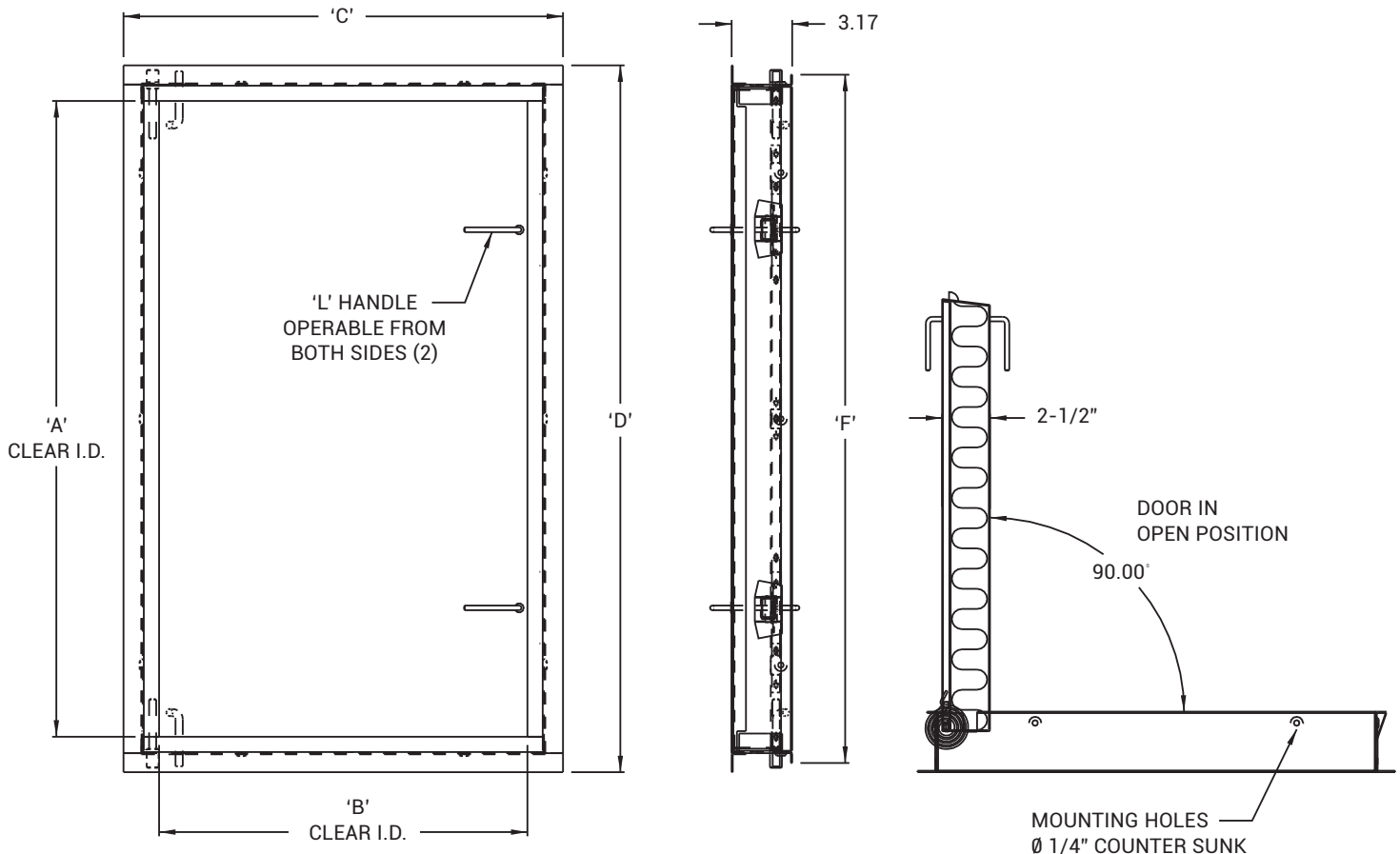

MANUFACTURED BY ACUDOR