



Quality Access Doors- FAST!

SUBMITTAL/TECHNICAL DATA SHEET

SKU: **BAC-F2DF**

DRYWALL INLAY ACCESS PANEL

WITH DRYWALL FLANGE - DETACHABLE

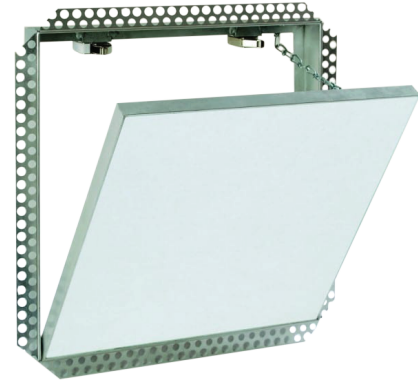

DESCRIPTION

The access panel consists of a welded aluminum frame and is available with 5/8" (15.9 mm) inlaid drywall and two latches.

Both an outer and an inner frame assembly consists of high grade aluminum which is bonded with a special welding process. For sizes 12" x 12" (305 mm x 305 mm) and up the access panels are equipped with a safety-system to prevent accidental opening. This safety system must be reattached if the hatch is removed.

The reveal of 1/16 of an inch (1.59 mm) is visible between the outer frame and door hatch. The concealed snap locks open the access panel when pressure is applied to the spring loaded latch side.

ADVANTAGE

- Superior engineering & innovative design
- Fast delivery
- Quick and easy installation
- Solid aluminum frame
- Flush installation in walls
- Available in moisture / mildew resistant green board and cement board

OPTIONS

- Screwdriver operated cam latch
- Screwdriver operated four-square cam latch
- Round Cylinder Lock with Key
- Mortise Cylinder Lock Preparation
- Hex Head Cam Latch
- Pinned Hex Head Cam Latch

CUSTOMIZED SOLUTIONS

Customized sizes can be produced in every dimension upon request. Drywall insert with screws on larger sizes than 24" x 24" (610 mm x 610 mm)

For a complete list of options visit www.BestAccessDoors.ca

DIMENSIONS AND APPEARANCE

>> CLICK TO VIEW ADDITIONAL DETAILS AND PRICING <<

AVAILABLE IN THE FOLLOWING STANDARD SIZES:

System F2DF CODE	Dimension			
	A		B	
	inch	mm	inch	mm
DF203203G127	8"	203	8"	203
DF305305G127	12"	305	12"	305
DF406406G127	16"	406	16"	406
DF508508G127	20"	508	20"	508
DF610610G127	24"	610	24"	610

* Rough opening is door size +3/8" (9mm)

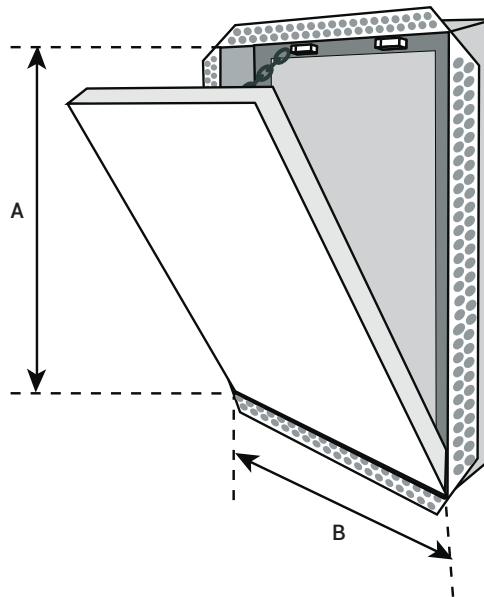

PROJECT DATA

Custom Sizes Available - Fast!

PROJECT NAME :	QTY	W	H	OPTIONS
ARCHITECT :				
DEALER :				
CONTRACTOR :				
LOCATION :	SPECIAL INSTRUCTIONS :			
DATE :	SUBMITTAL APPROVAL : (signature or stamp)			
TAGGING INSTRUCTIONS :				

Scan or Click



To view Pricing and Additional Product Info.

TELEPHONE:
1-800-483-0823
FAX:
1-888-828-6021



385 WILSON STREET EAST,
SUITE 302
ANCASTER, ON, L9G 2C1
CANADA



WEBSITE:
www.BestAccessDoors.ca
E-MAIL:
info@bestaccessdoors.ca