

MEDIUM SECURITY ACCESS DOOR FOR ALL SURFACE TYPES

BA-MDS

INSTALLATION

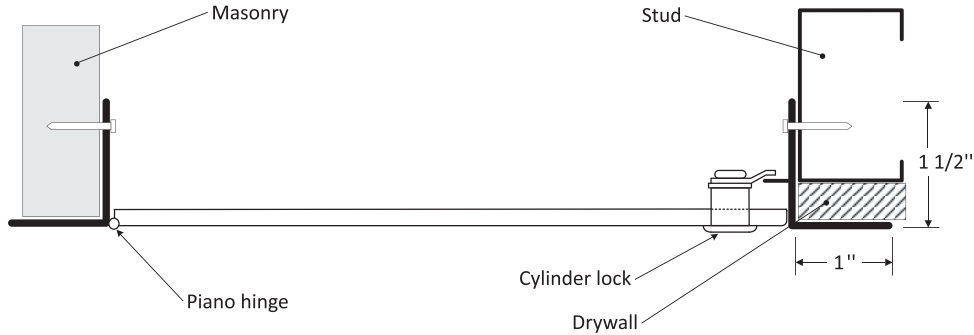

DIMENSIONS AND APPEARANCE

LEED ready: This product contributes to LEED® credits.

DOOR SIZE - W x H INCHES (MM)	NUMBER OF LOCKS	WEIGHT	
		LBS	KG
12 x 12 (304 x 304)	1	6	2.7
16 x 16 (406 x 406)	1	7	3.2
18 x 18 (457 x 457)	1	11	5
24 x 24 (609 x 609)	1	19	8.6
24 x 30 (609 x 762)	2	24	10.9
24 x 36 (609 x 914)	2	27	12.2
36 x 36 (914 x 914)	2	41	18.6
Rough wall opening is door size + 1/4" or + 6mm			

**Your odd sizes:
Made in 5 days**

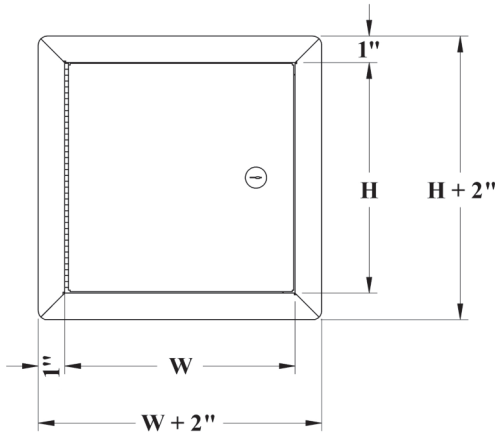

DESCRIPTION AND MATERIAL SPECIFICATION

- Material:** 14 gauge galvalneal steel
- Hinge:** continuous piano type
- Lock / latch:** key operated cylinder cam latch
- Finish:** high quality white powder coat primer
- Packaging:** individually wrapped, 1 per box

POPULAR OPTIONS For complete list of options go to: www.BestAccessDoors.ca

- Material:** stainless steel 304 #4 (brushed finish)
- Lock / latch:** mortise preparation for cylinder (cylinder optional), pinned hex head cam latch, 4" key handle operated cam latch, mortise deadbolt lock



PROJECT DATA

PROJECT NAME:	QTY	W	H	OPTIONS
ARCHITECT:				
DEALER:				
CONTRACTOR:				
LOCATION:	SPECIAL INSTRUCTIONS:			
DATE:				
TAGGING INSTRUCTIONS:	SUBMITTAL APPROVAL: (signature or stamp)			