



Quality Access Doors - FAST !



# Floor Door Recessed 1" for Ceramic Tile/Concrete BA-FT-8050

## Application

- Designed for interior and exterior applications that require an access opening that will blend in with the surrounding floor material

## Product Features

- Recessed 1" to accommodate ceramic tile/concrete flooring
- Door panel is equipped with a flush aluminum drop handle and an automatic hold open arm



## BA-FT-8050 Floor Door Specifications:

**Material:** Aluminum door and frame; stainless steel hinges and hardware

**Door:** 1/4" smooth aluminum plate reinforced for live load of 150 pounds/sq. ft.

Extruded edging is welded to door panel, providing a 1" recess

**Frame:** Channel frame fabricated from aluminum extrusion with 1 1/2" drainage coupling and integral 1" anchor flange

**Hinge:** Stainless steel continuous piano hinge

**Opening Device:** Automatic Hold-Open Arm with red vinyl grip allows door panel to open to 90 degrees, locking door in open position, and allowing for easy control when closing door panel. Stainless Steel Open Compression Springs provide lift assist.

**Standard Latch:** Stainless steel slam lock with a fixed inside handle, removable outside handle, and removable threaded plug

**Finish:** Mill finish with bituminous coating applied to exterior of frame

## AVAILABLE SIZES (Special sizes available upon request)

NOMINAL DOOR SIZE W X H		WEIGHT PER DOOR	
inches	mm	lbs.	kg.
24 X 24	610 X 610	70	31.8
24 X 30	610 X 762	80	36.4
24 X 36	610 X 914	90	41
30 X 30	762 X 762	110	49.9
30 X 36	762 X 914	100	45.4
36 X 36	914 X 914	115	52.2
42 X 42	1067 X 1067	140	63.6
48 X 48*	1220 X 1220	195	88.5
48 X 72*	1220 X 1829	265	120.3
60 X 60*	1524 X 1524	275	124.9

\*Double Leaf

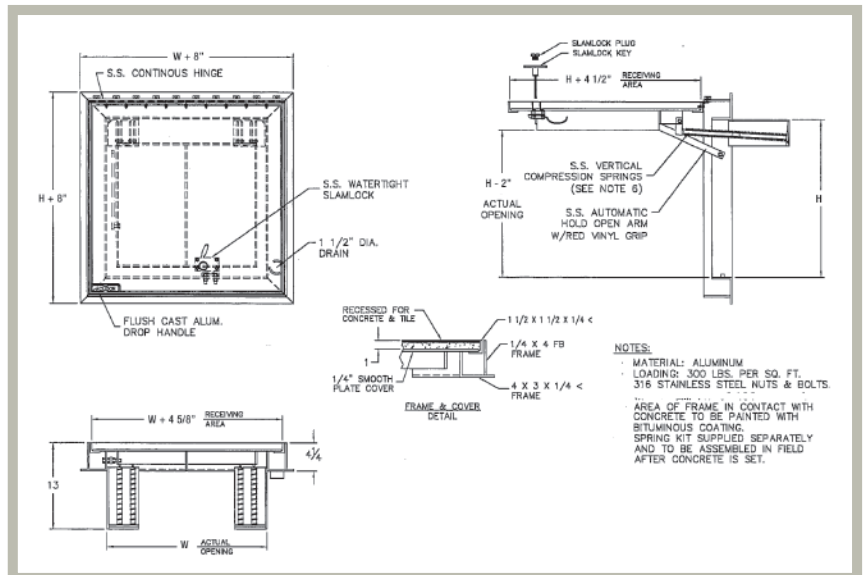

For detailed specifications see submittal sheet