



Quality Access Doors - FAST !



Floor Door Non Hinged, Flush Diamond Plate BA-FD-8060

Application

- Designed for interior and exterior applications that require an access opening that will blend in with the surrounding floor material

Product Features

- Flush Diamond Plate door panel
- Door panel removable via screws

BA-FD-8060 Floor Door Specifications:

Material: Aluminum

Door: 1/4" aluminum diamond plate reinforced for the live load of 150 pounds/per sq. ft.

Frame: 1" x 1" aluminum angle designed to be cast into concrete

Standard Latch: Door panel is secured to frame with 1/4" x 1" flat head screws

Finish: Mill finish

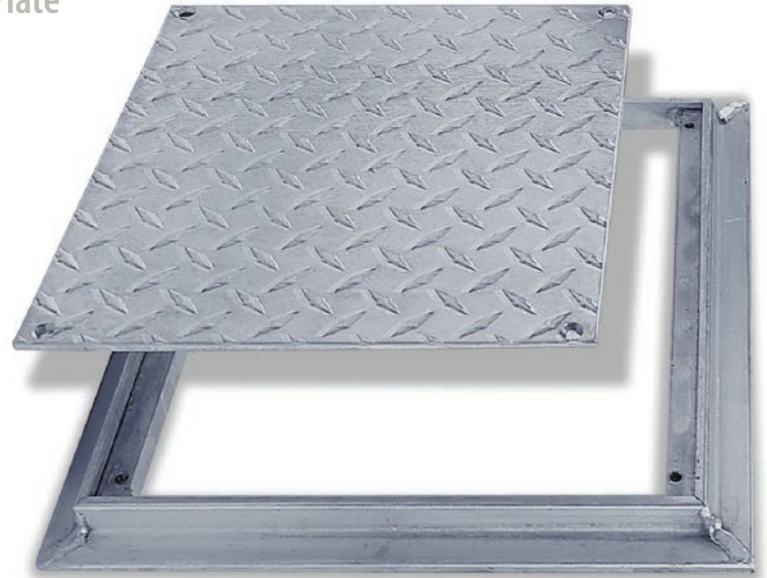

AVAILABLE SIZES *(Special sizes available upon request)*

NOMINAL DOOR SIZE W X H		WEIGHT PER DOOR	
inches	mm	lbs.	kg.
8 X 8	203 X 203	4	1.8
12 X 12	305 X 305	6	2.7
18 X 18	457 X 457	12	5.5
24 X 24	610 X 610	24	10.9
For detailed specifications see submittal sheet			

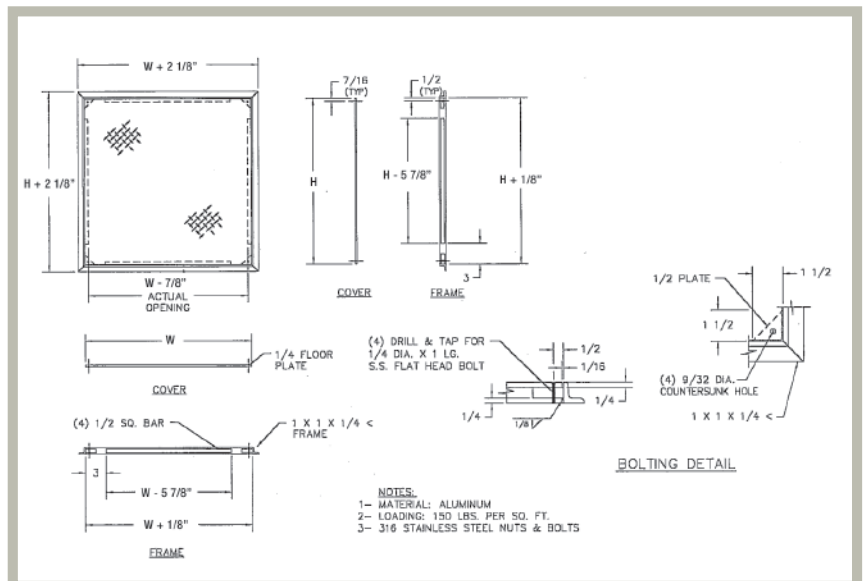

For more information, contact Best Access Doors

www.BestAccessDoors.ca

Phone: 1-800-483-0823

Fax: 1-888-828-6021

Email: info@BestAccessDoors.ca