



Quality Access Doors - FAST !



Floor Door 300 lb./sqft loading BA-FA-300

Application

- Designed for interior and exterior applications where watertightness is not required

Product Features

- Angle frame construction with integral anchor flange is designed to be cast into concrete
- When bolting into an existing opening, retrofit frame designs are available
- Diamond plate door panel is equipped with a flush aluminum drop handle and an automatic hold open arm

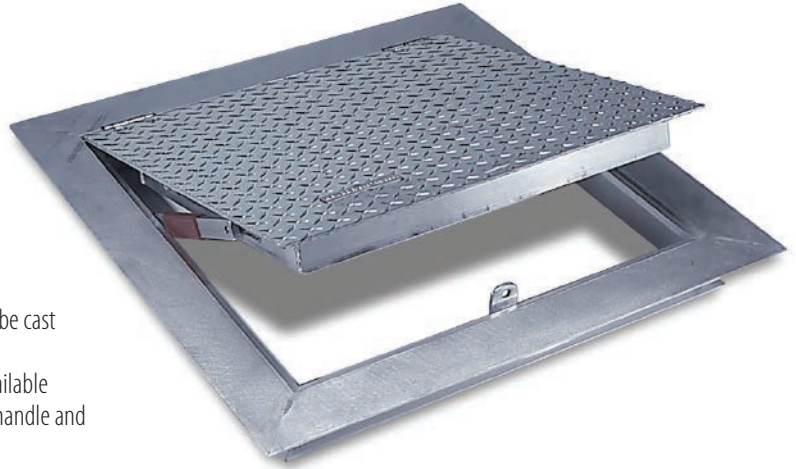

BA-FA-300 Floor Door Specifications:

Material: Aluminum door and frame; stainless steel hinges and hardware

Door: 1/4" aluminum diamond plate reinforced for live load of 300 pounds/sq ft.

Frame: Angle frame fabricated from aluminum extrusion with an integral 1" anchor flange

Hinge: Stainless steel butt hinges with tamperproof stainless steel bolts and nuts

Opening Device: Automatic hold open arm with red vinyl grip allows door panel to open to 90 degrees, locking door in open position, and allowing for easy control when closing door panel. When required, stainless steel compression springs can be provided to add lift assistance.

Standard Latch: Flush aluminum drop handle with staple for padlock. Also available recessed padlock provision: st/stl slamlock

Finish: Mill finish, with optional bituminous coating on exterior of frame

AVAILABLE SIZES (Special sizes available upon request)

NOMINAL DOOR SIZE W X H		WEIGHT PER DOOR	
inches	mm	lbs.	kg.
24 X 24	610 X 610	40	18.2
24 X 30	610 X 762	50	22.7
24 X 36	610 X 914	55	25
30 X 30	762 X 762	55	25
30 X 48	762 X 1220	80	36.4
36 X 36	914 X 914	75	34
36 X 48	914 X 1220	90	41
42 X 42	1067 X 1067	95	43.1
48 X 48*	1220 X 1220	120	54.5
48 X 72*	1220 X 1829	165	74.9
60 X 60*	1524 X 1524	170	77.2

*Double Leaf

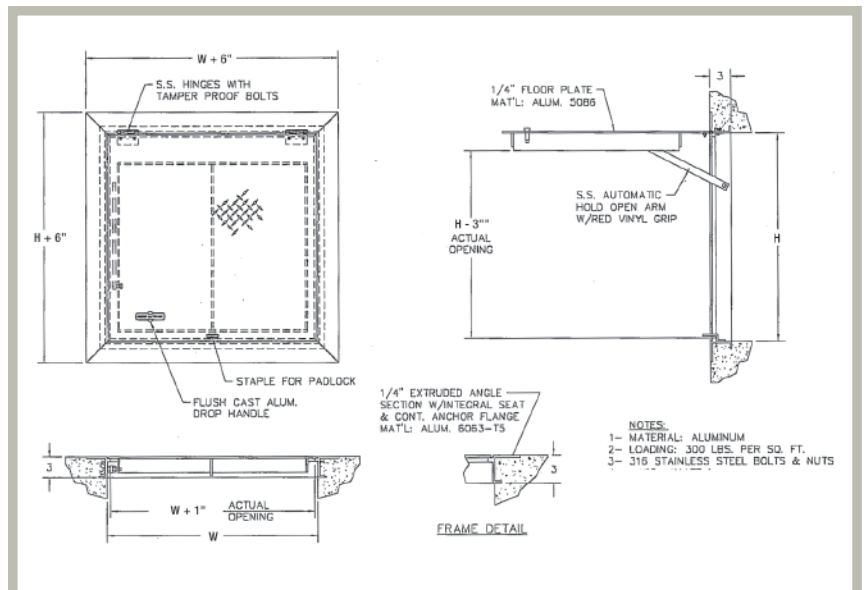

For detailed specifications see submittal sheet