

# Access Panel - Exterior/Weather resistant

## System EXT

**NEW**



Shown with 1/4 turn latch

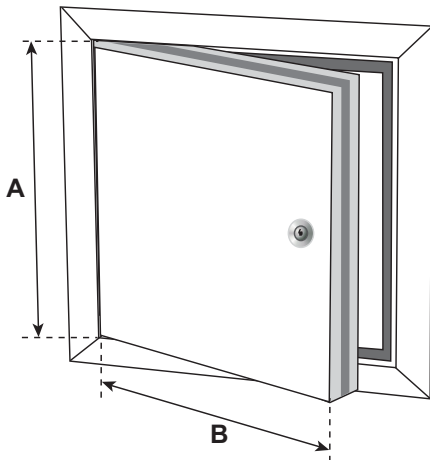

### Description

The EXT is a universal, exterior, non-rated access panel. The 20 ga /1mm door provides strength and rigidity and features a key operated turn latch closure. The door is equipped with a continuous stainless steel piano hinge and suitable for left- or right-hand operation. It consists of a welded inner and outer aluminum frame with an aluminum inlay.

**Insulation:** 1 1/2" polyurethane

**Gasketing:** Extruded santoprene

The door can be supplied with an optional non-locking or locking handle. Dual-acting non-locking handles enable to open this door from inside or outside.

### Capabilities

This popular panel can be mounted in exterior or interior walls. Suitable for mechanical contractors.

Exterior/  
Weather resistant

EXT access panels are available in the following standard sizes:

System Code	Dimensions	
	A inch   mm	B inch   mm
EXT203203AL	8"   203	8"   203
EXT305305AL	12"   305	12"   305
EXT406406AL	16"   406	16"   406
EXT457457AL	18"   457	18"   457
EXT508762AL	20"   508	30"   762
EXT610610AL	24"   610	24"   610
EXT610762AL	24"   610	30"   762
EXT610914AL	24"   610	36"   914

### Customized solutions

Customized sizes can be produced in every dimension upon request.

### Options

- TL** 1/4 turn latch
- LH** Locking handle (exterior only 1 per door)
- NH** Non-locking handle
- M** Mortise lock preparation (1 1/8")

### Advantages of FF Systems Panels

- Superior engineering & innovative design
- Fast delivery
- Quick and easy installation
- Economical solution
- Universal door



Rough opening is door size + 3/8" (9 mm)