

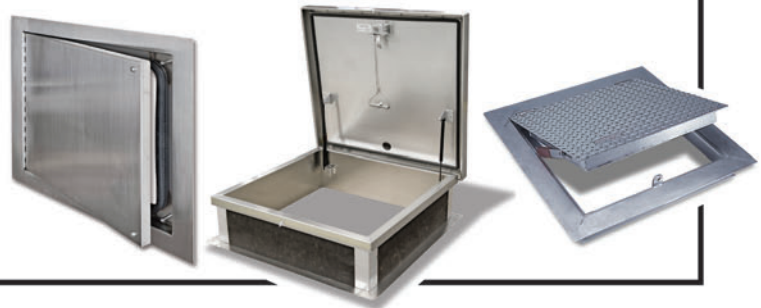

Quality Access Doors - FAST !



DUCT DOORS for fibreglass ducts

BA-CD-5080-F

Application

- Economical access to fibreglass ducts

Product Features

- These doors are for use in low to medium pressure fibreglass ducts
- Double cam - no hinge, removable door panel

Options:

- ALUMINUM • STAINLESS STEEL

BA-CD-5080-F Duct Access Door Specifications:

Door: 24 gauge galvanized steel

Frame: 24 gauge galvanized steel

Insulation: 1" Micro-Airc M/F type 475

Gasketing: 1/8" thick by 1/2" wide closed cell neoprene gasketing between door and frame. 1/16" thick by 1 1/2" adhesive bonded gasket between frame to duct

Latch: Self tightening, hand operated cam latch



STANDARD SIZES (Special sizes available upon request)

NOMINAL DOOR SIZE W X H		WEIGHT PER DOOR		
inches	mm	Latches	lbs.	kg.
6 X 6	150 X 150	2	1	0.5
8 X 8	200 X 200	2	1.25	1
10 X 10	250 X 250	2	2	0.9
12 X 12	300 X 300	2	2.5	1.1
14 X 14	350 X 350	4	3.25	1.5
16 X 16	400 X 400	4	4	1.8
18 X 18	450 X 450	4	5.5	2.5
24 X 24	610 X 610	4	9	4.1

Duct opening is the same as the Nominal Door Size
For detailed specifications see submittal sheet

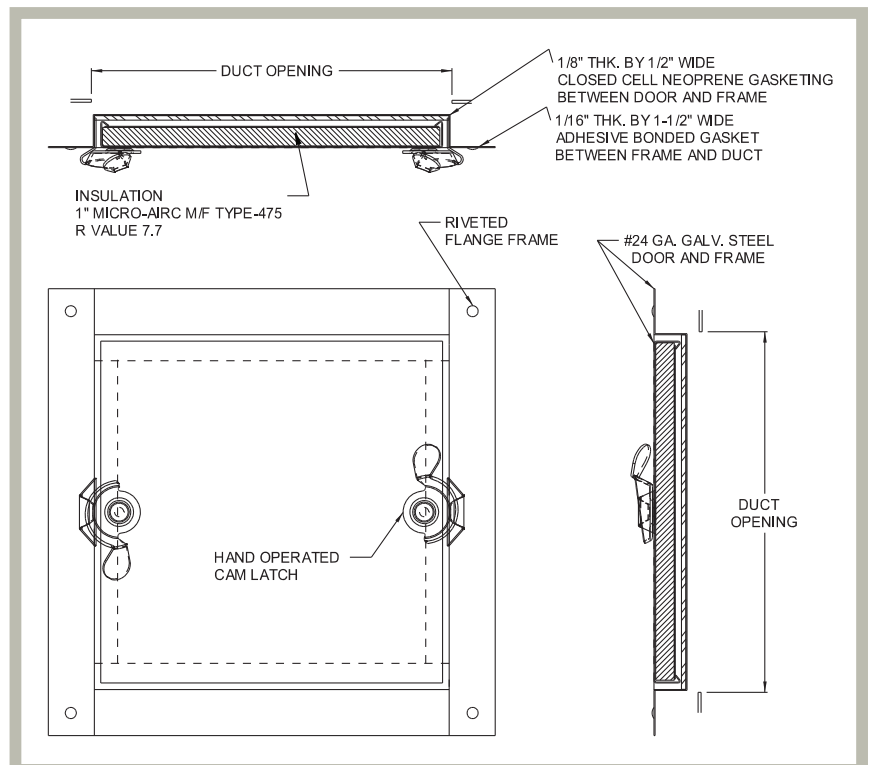

For more information, contact Best Access Doors

www.BestAccessDoors.ca

Phone: 1-800-483-0823

Fax: 1-888-828-6021

Email: info@BestAccessDoors.ca